

# Portfolio

2021 - 2024

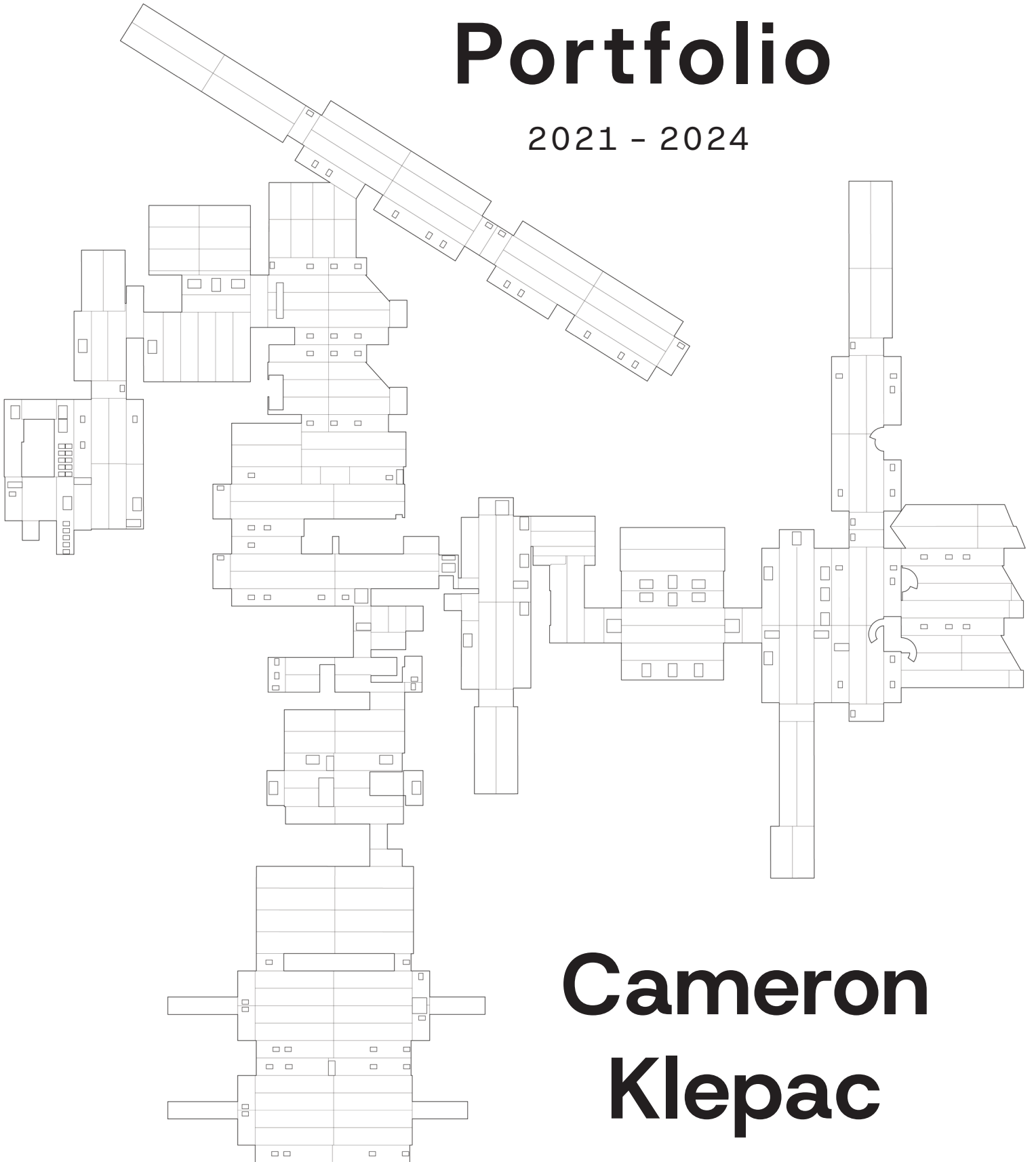

**Cameron  
Klepac**

## Cameron Klepac, Assoc. AIA

(936)-827-3450

cameronklepac@cameronklepac.com

@ cameron\_g\_klepac



### EDUCATION

**Bachelor of Science – Civil Engineering**

– 2021, 3.0 GPA

Texas Tech University, Lubbock, TX

**Master of Architecture – 2024, 3.7 GPA**

Texas A&M University, College Station, TX

### EXPERIENCE

**AIA Austin – Volunteer**

Austin, TX , August 2024 – Current

- Active committee member of the Housing Advocacy Committee and LGBTQ+ Alliance Committee.
- Assisted with running the AIA Design Excellence Conference.
- Assisted with running the AIA Austin Homes Tour.

**Digital Content Manager – TAMU Energy Systems Lab**

College Station, TX , August 2022 – May 2024

- Designed new web graphics and pages for lab websites.

**Project Estimator – K&R Mechanical Services**

Houston, TX , May 2020 – July 2020

- Created bid budgets, up to \$150,000, for HVAC and plumbing work.
- Drafted project proposals and contracts to clients.
- Communicated with contractors and clients to deliver accurate and quality building information.

### SKILLS

**General:**

3D Modeling

Rendering

Digital Illustration

Parametric Modeling

Physical Model Making

Research

Photography

Artificial Intelligence

Space Programming

Writing

Web Design

Public Speaking

**Software:**

Revit

Rhino

Adobe Creative Suite

D5 Render

Enscape

Grasshopper

AutoCAD

ClimateStudio

GAN AI

WordPress

## Unreal Estate: M. Arch. Final Study

Pages 1 – 18

## Starting Out: Alley Lot Housing – Arch 602

Pages 19 – 26

## Architecture for Art: Gallery for Downton Bryan – Arch 603

Pages 27 – 36

## Art for Architecture: Community Center in Dallas – Arch 605

Pages 37 – 46

# Unreal Estate: M. Arch Final Study

Unreal Estate ventured into a realm where designing transcended traditional architectural paradigms. Rather than focusing on crafting a static structure, the project's core lay in developing systems capable of dynamically generating architectural forms.

Through a collaborative effort with Professor Ben Ennemoser, a bespoke Grasshopper script was crafted from scratch, based on pre-fab standards. This script served as the backbone, driving the parametric generation of the project's form with precision and automation.

A simple module for the interior space was conceived, fostering a simple yet versatile framework for room layouts. This modular system, coupled with the parametric script, laid the groundwork upon which intricate details and design nuances were later overlaid.

Despite its apparent simplicity, this framework harbors an extraordinary capacity to produce a wide spectrum of Cross-Laminated Timber (CLT) mat-buildings across diverse scales. The intricate details for such structures were meticulously developed in a comprehensive and catalog-like manner.

Nestled within the unassuming terrain of Plum Grove, TX, the project transcended mere architectural experimentation. It served as a catalyst for pushing the boundaries of conventional design methodologies, instigating a profound reassessment of my approach to design.

Grasshopper Script:

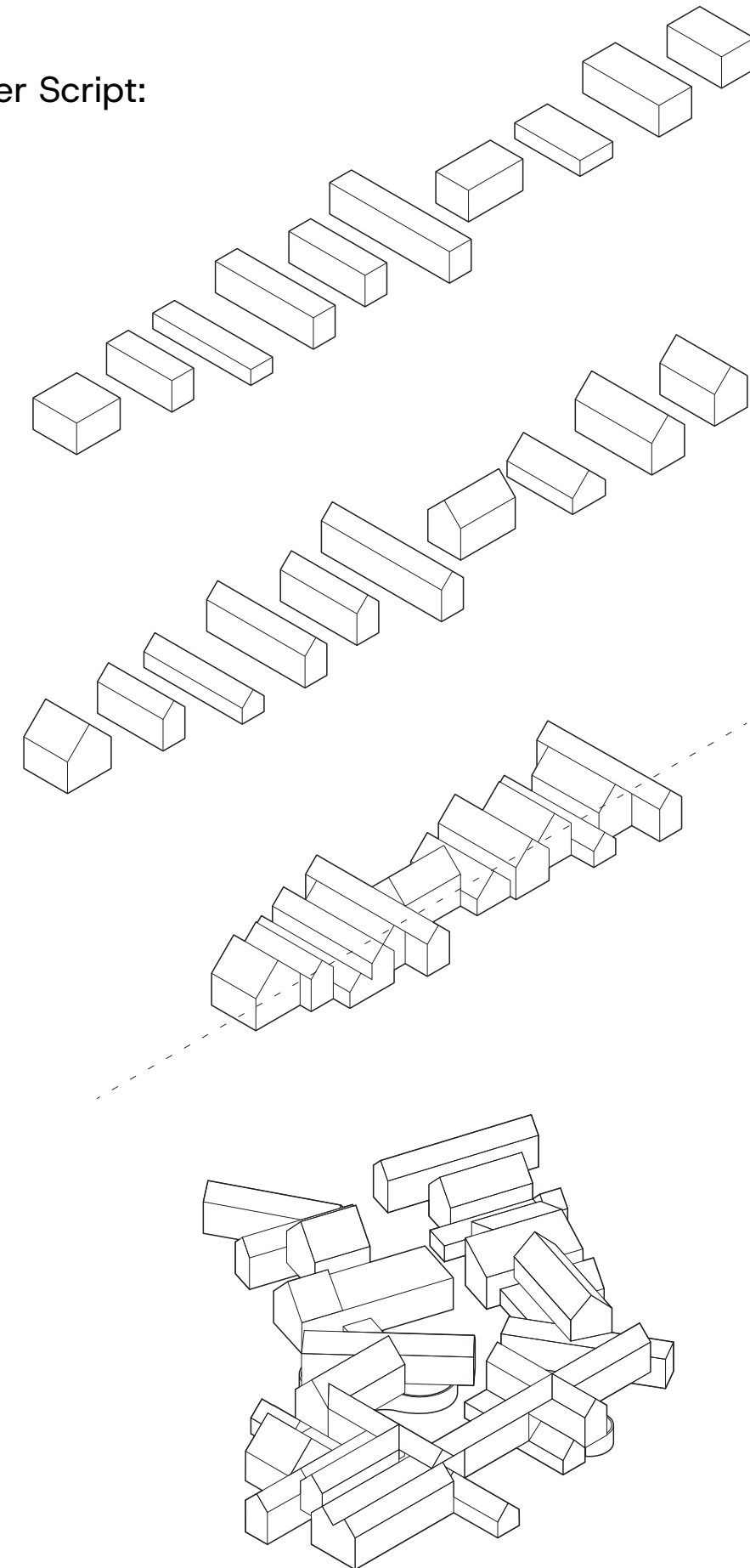

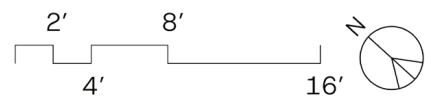
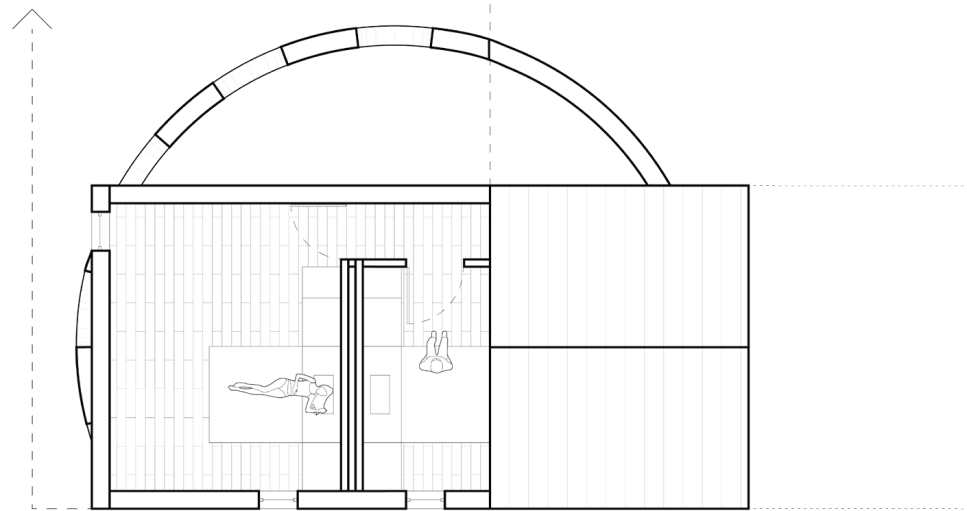
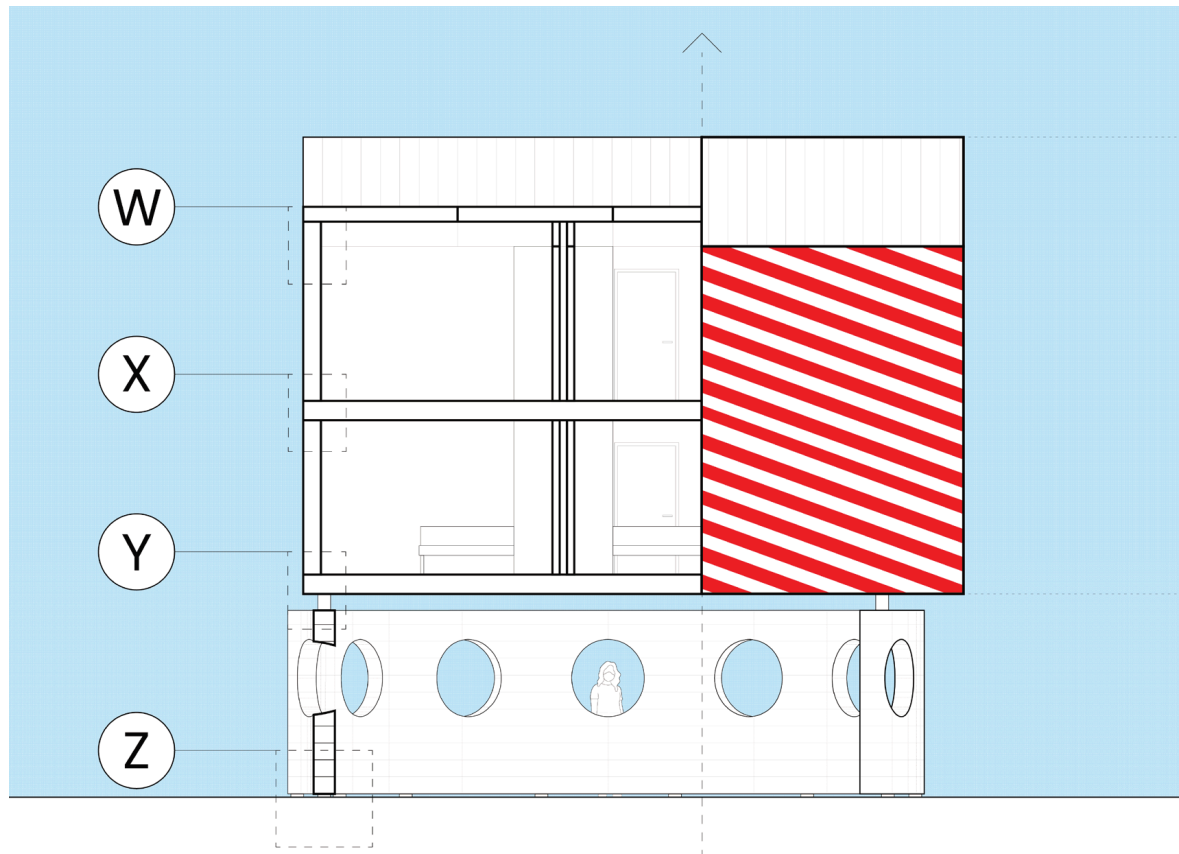

1. Corrugated metal roof

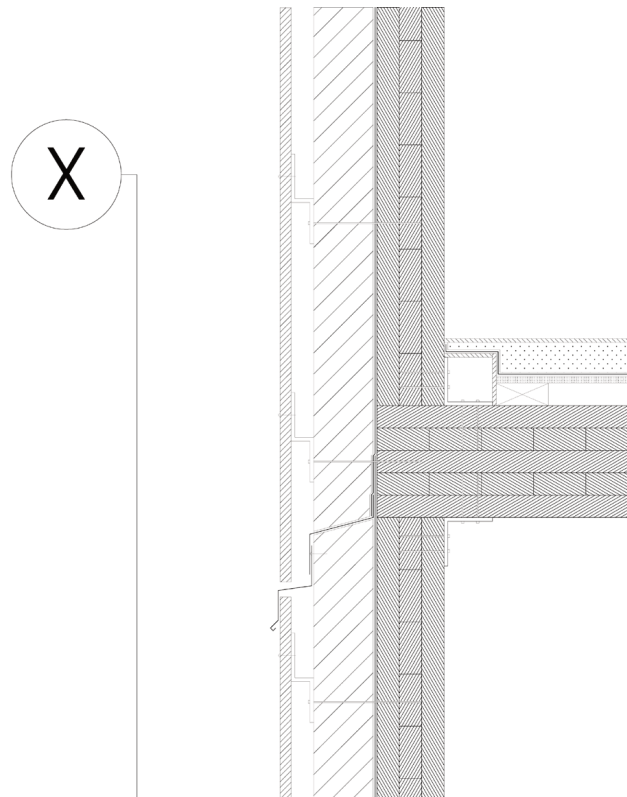
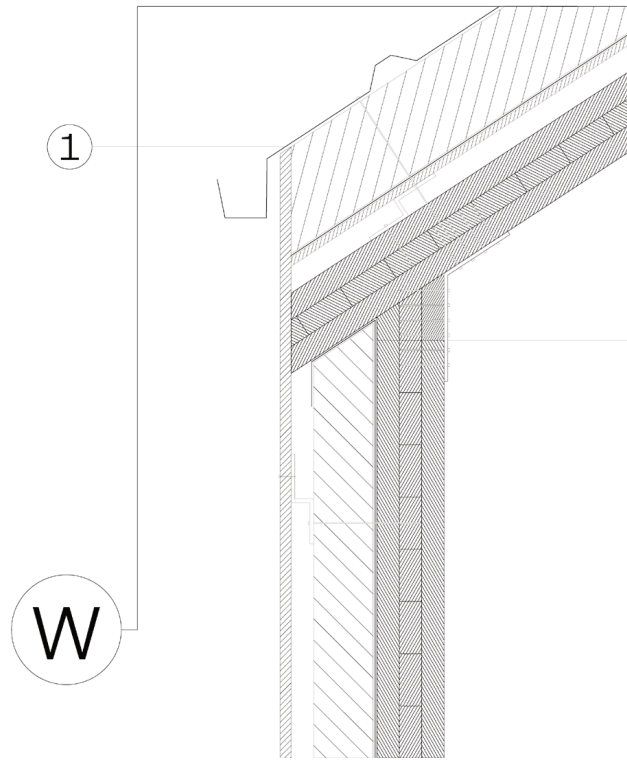

- 1. Threaded rod with bolts and washer
- 2. Steel W-beam
- 3. Anchor bolts with washers
- 4. 3D Printed wood pulp and resin wall

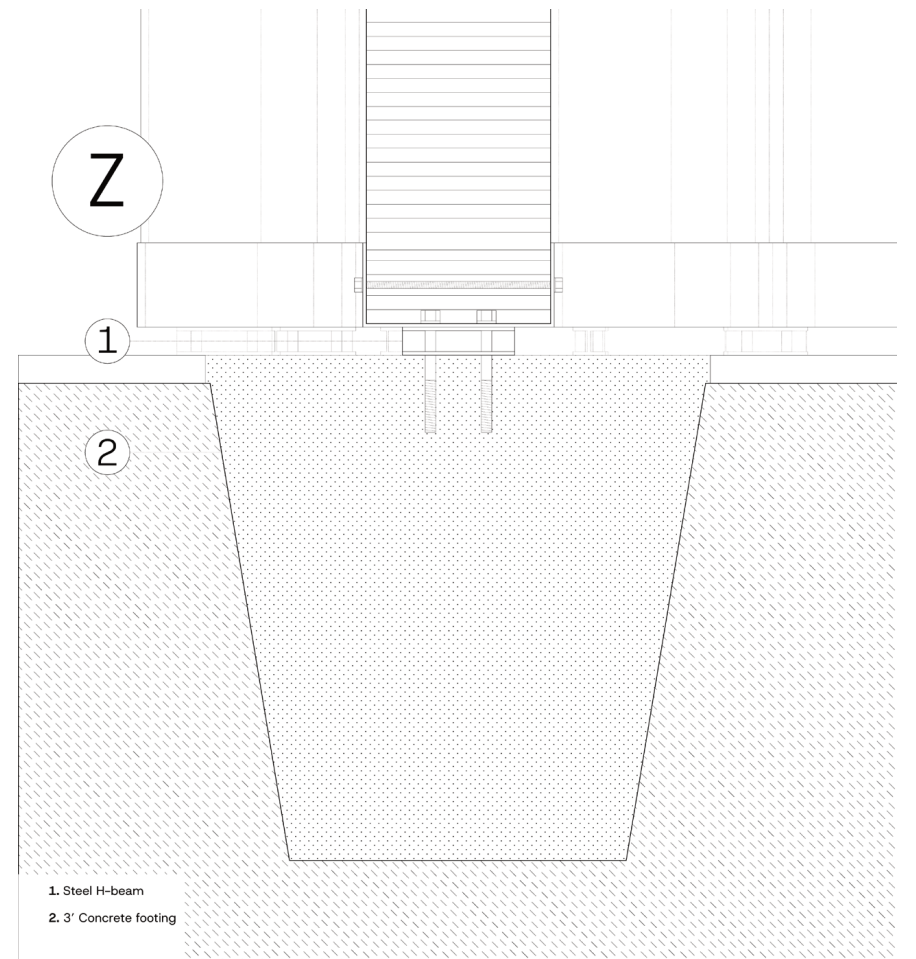
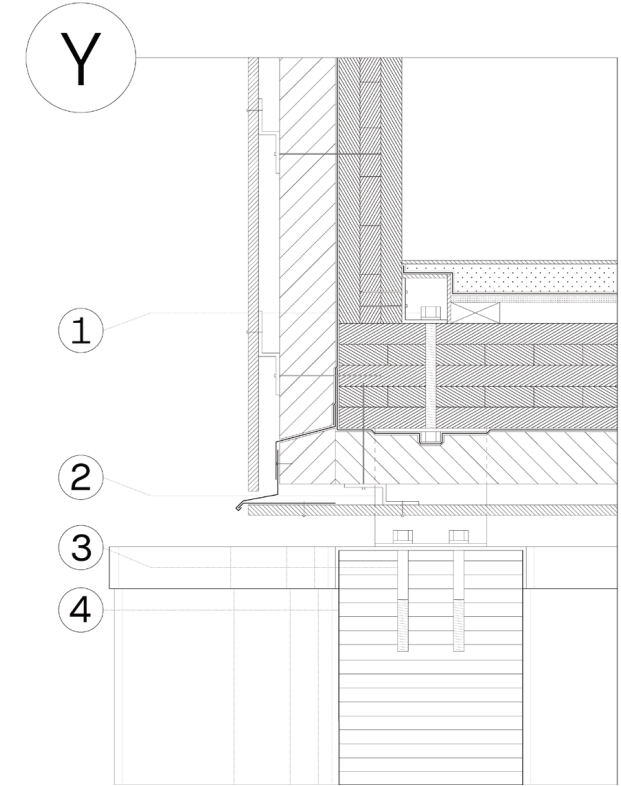



Interior Module:

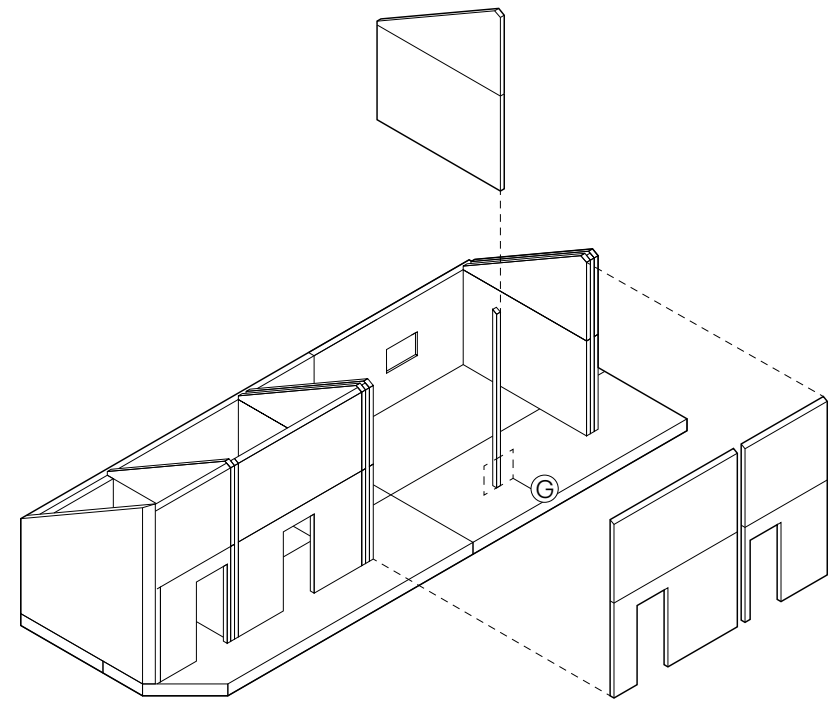
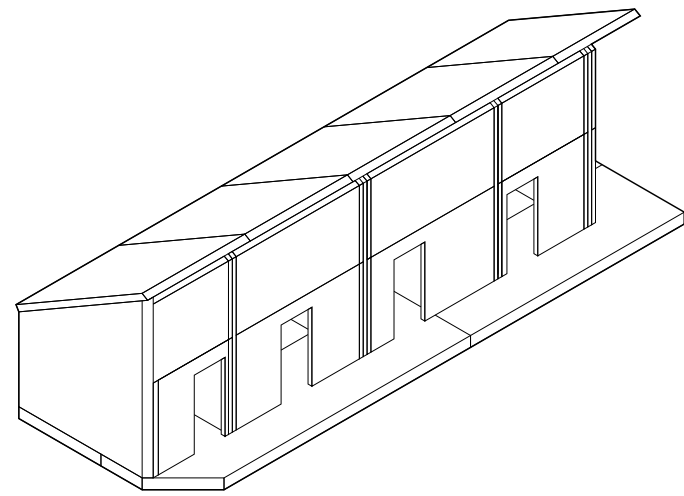
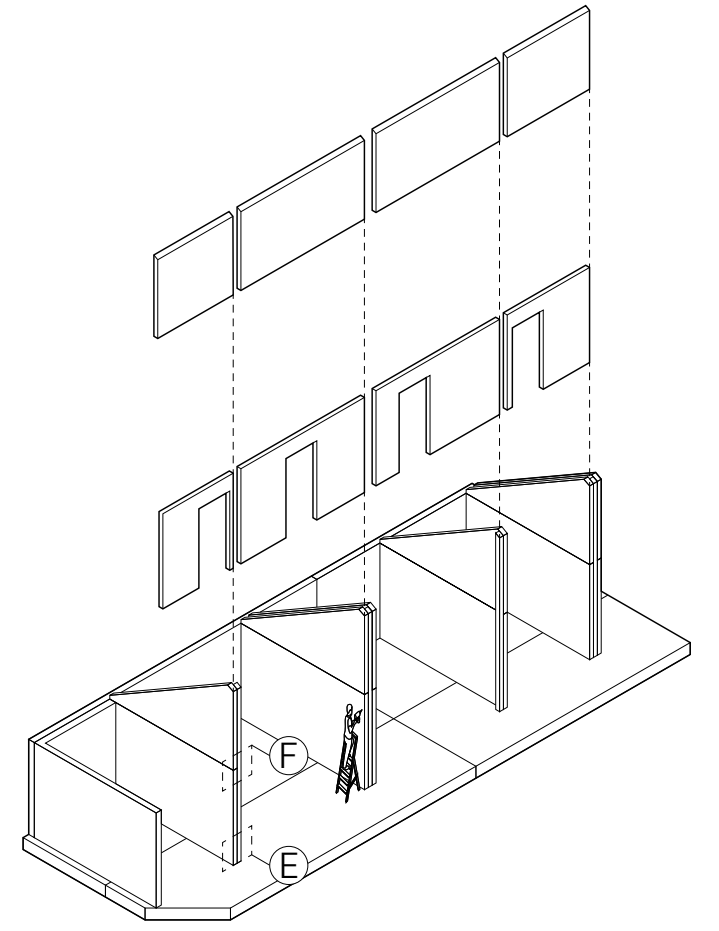
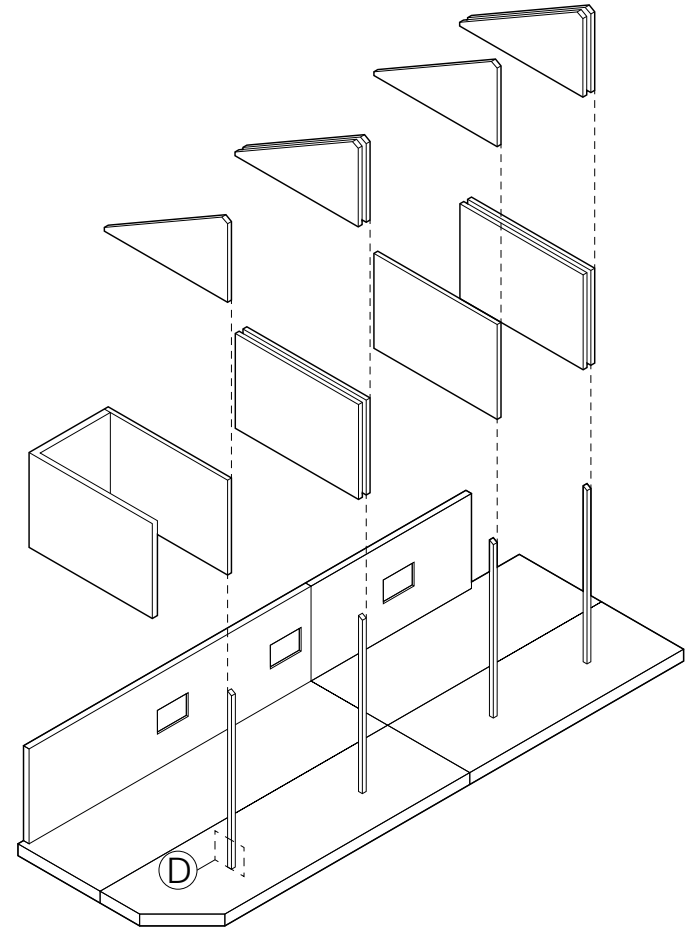
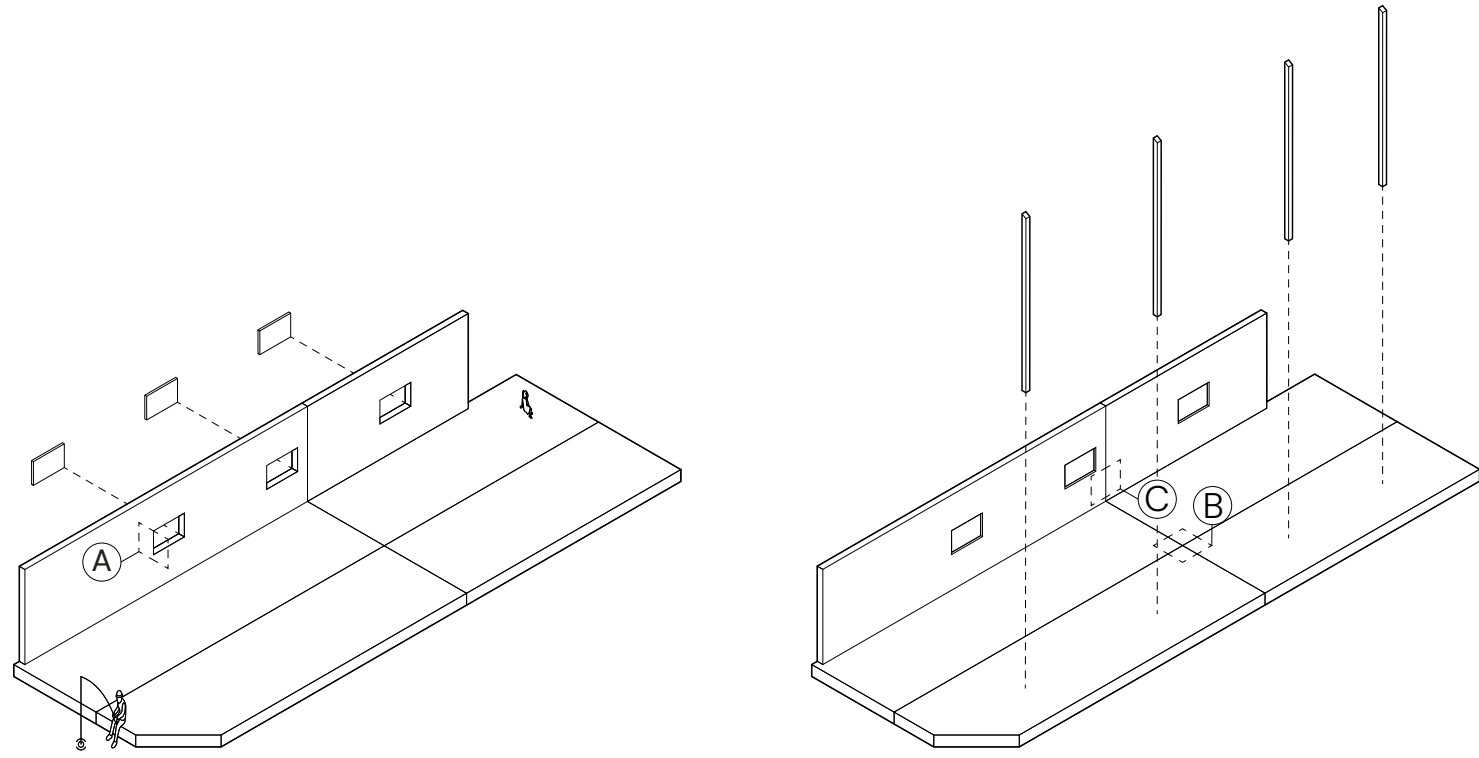

- 1. Plywood cladding
- 2. Air barrier and cladding bracket
- 3. Window flexible flashing membrane
- 4. Window head flashing and closure
- 5. 4" Rigid insulation
- 6. WRB sealant over backer rod
- 7. 2-Pane sliding window system
- 8. 3-Ply CLT wall panel
- 9. Plywood sheathing

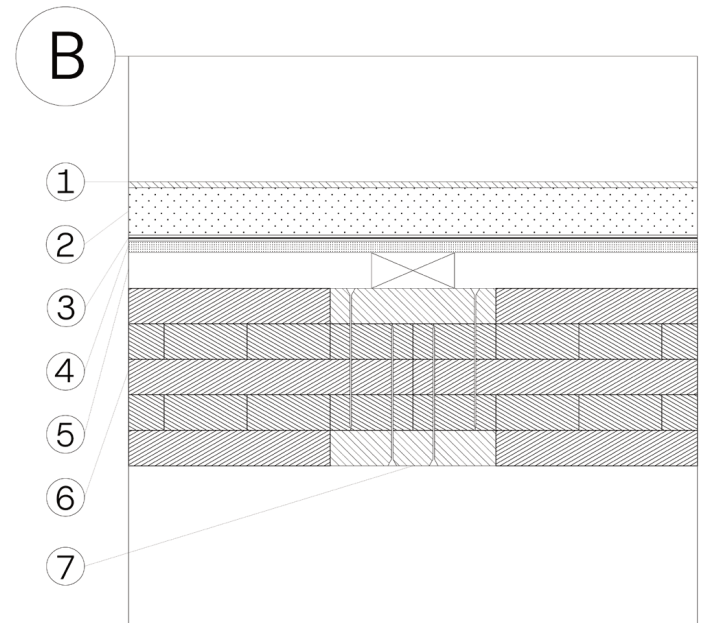
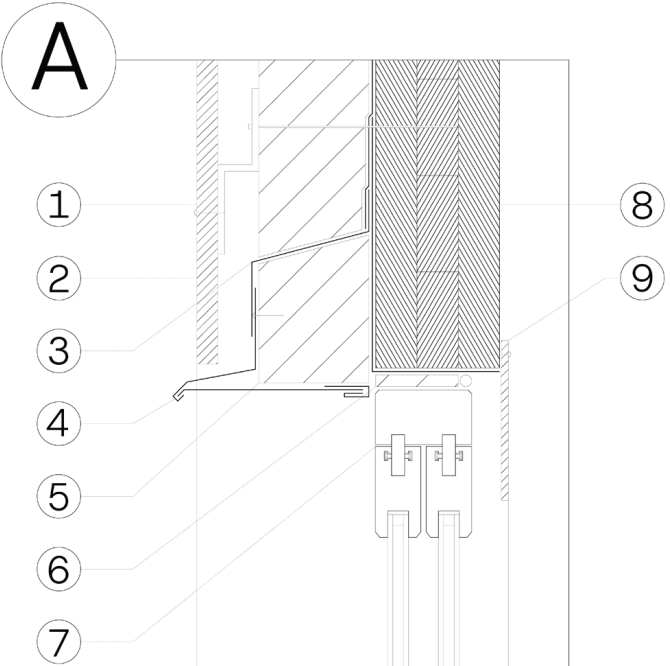

- 1. Vinyl flooring
- 2. 2" Concrete screed
- 3. WRB Membrane
- 4. Acoustic paneling
- 5. 2x4 and air cavity
- 6. 5-ply CLT floor panel
- 7. SCL Spline with self-tapping screws

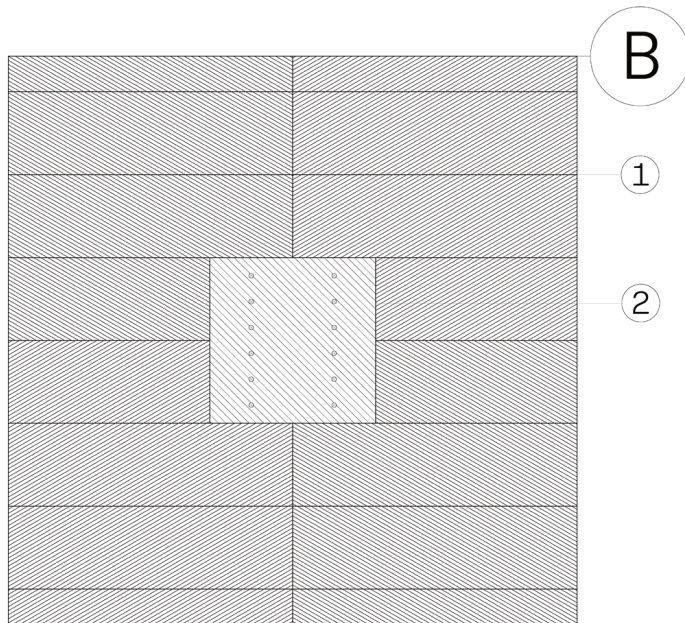

- 1. 5-Ply CLT floor panels
- 2. Structural composite lumber spline with self-tapping screws

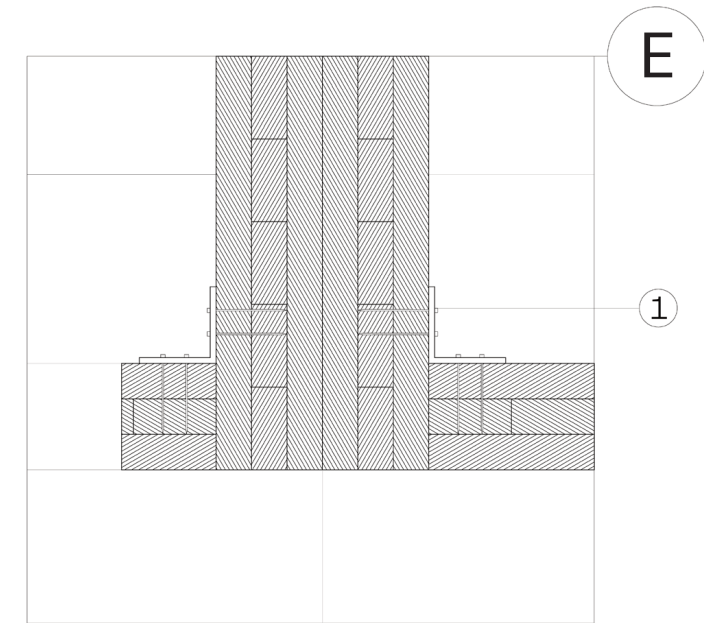

- 1. Steel bracket with self-tapping screws

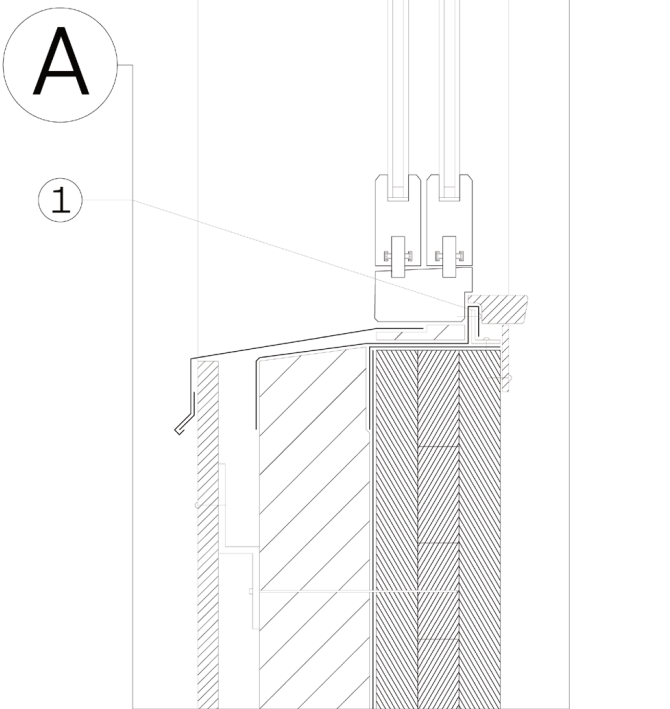

- 1. Air barrier and WRB sealant between window and metal back dam angle

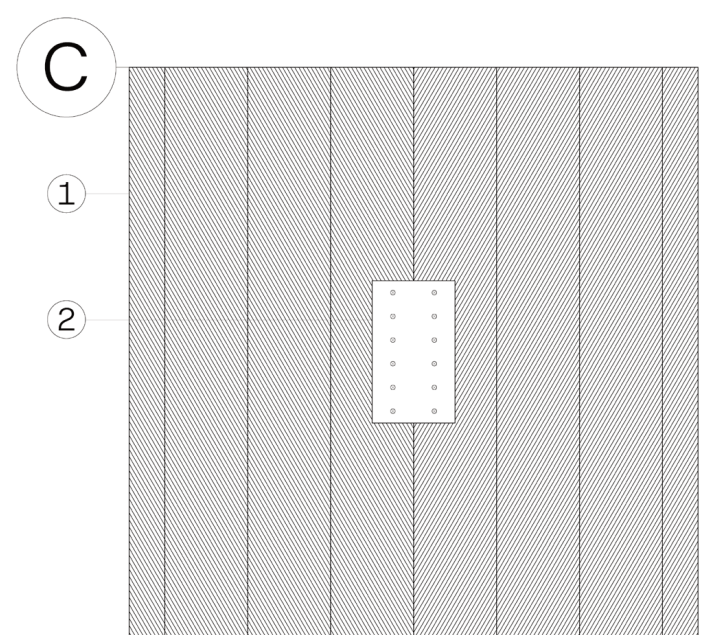
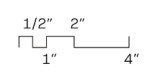

- 1. 3-Ply CLT wall panels
- 2. Steel bracket with self-tapping screws

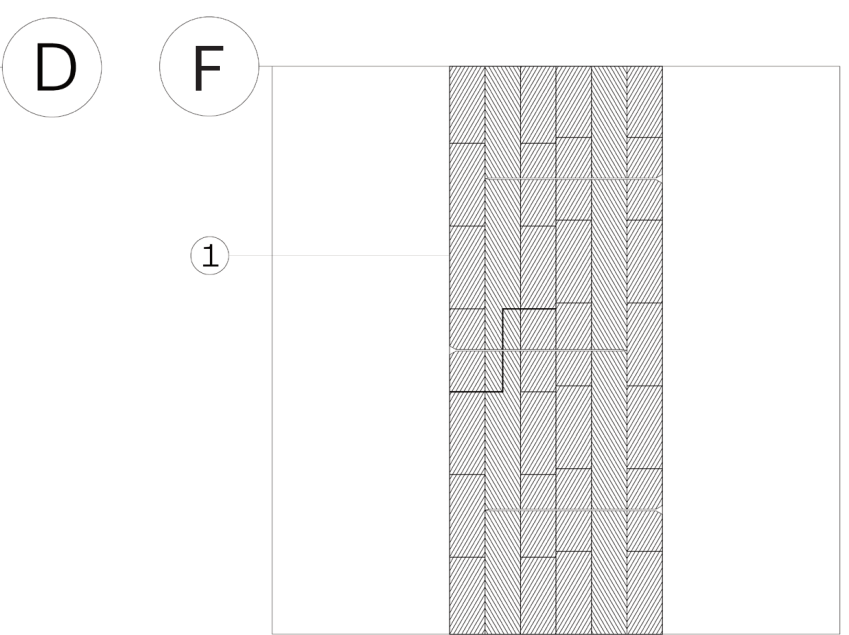
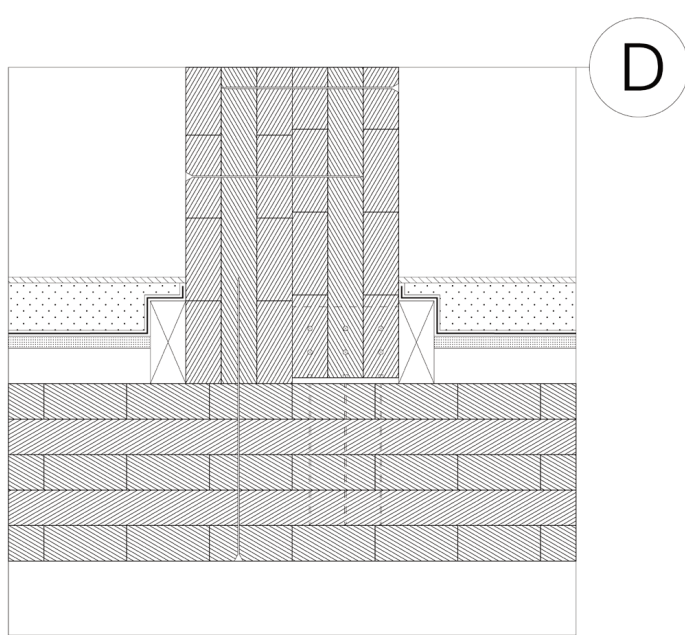

- 1. 2, 3-Ply CLT wall panels with half-lap joint





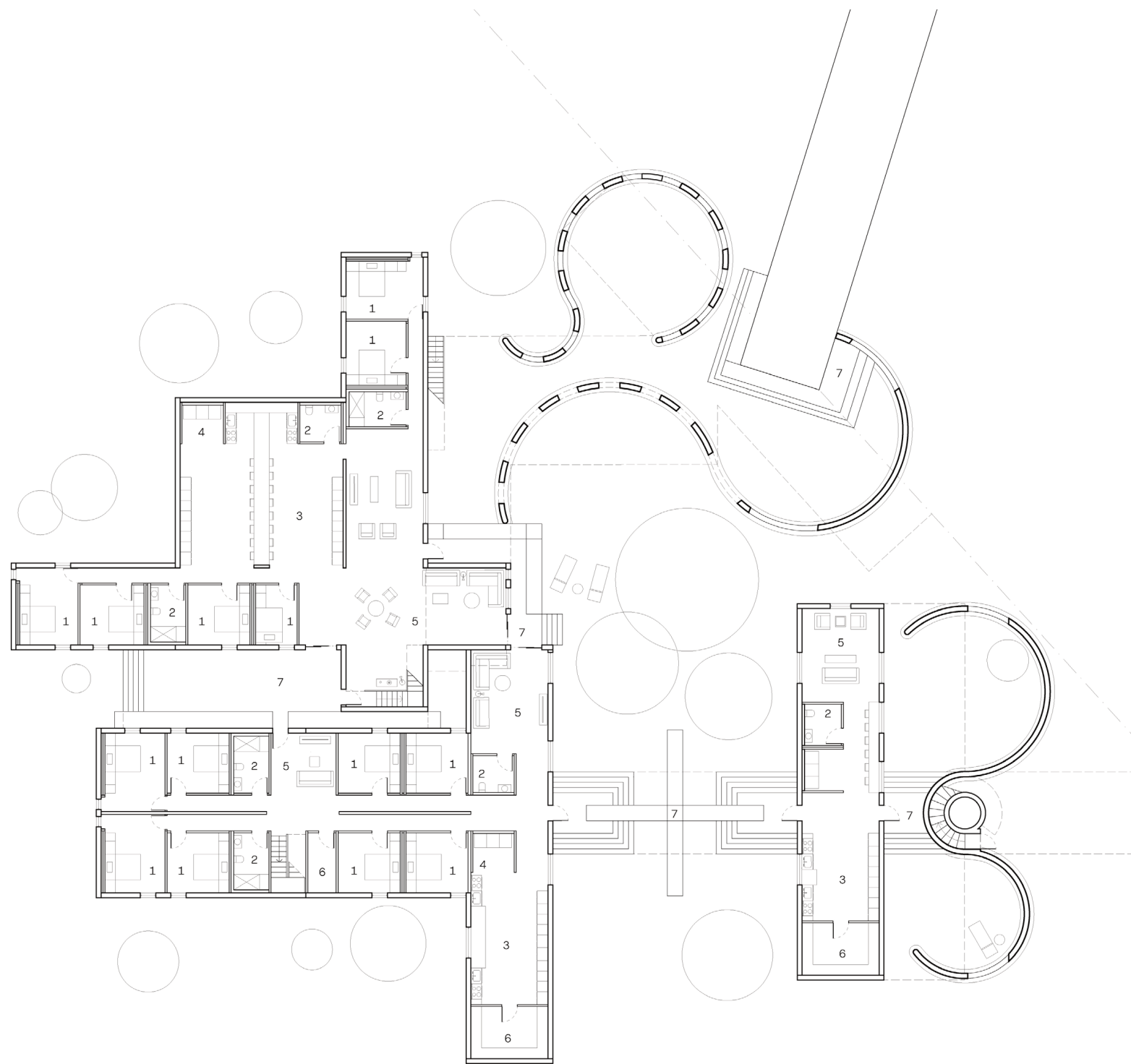

Ground Floor Plan

- |                       |                             |
|-----------------------|-----------------------------|
| 1 - Bedroom           | 5 - Community Living Space  |
| 2 - Bathroom          | 6 - Community Storage Space |
| 3 - Community Kitchen | 7 - Porch                   |
| 4 - Community Laundry | 8 - Rooftop Deck            |

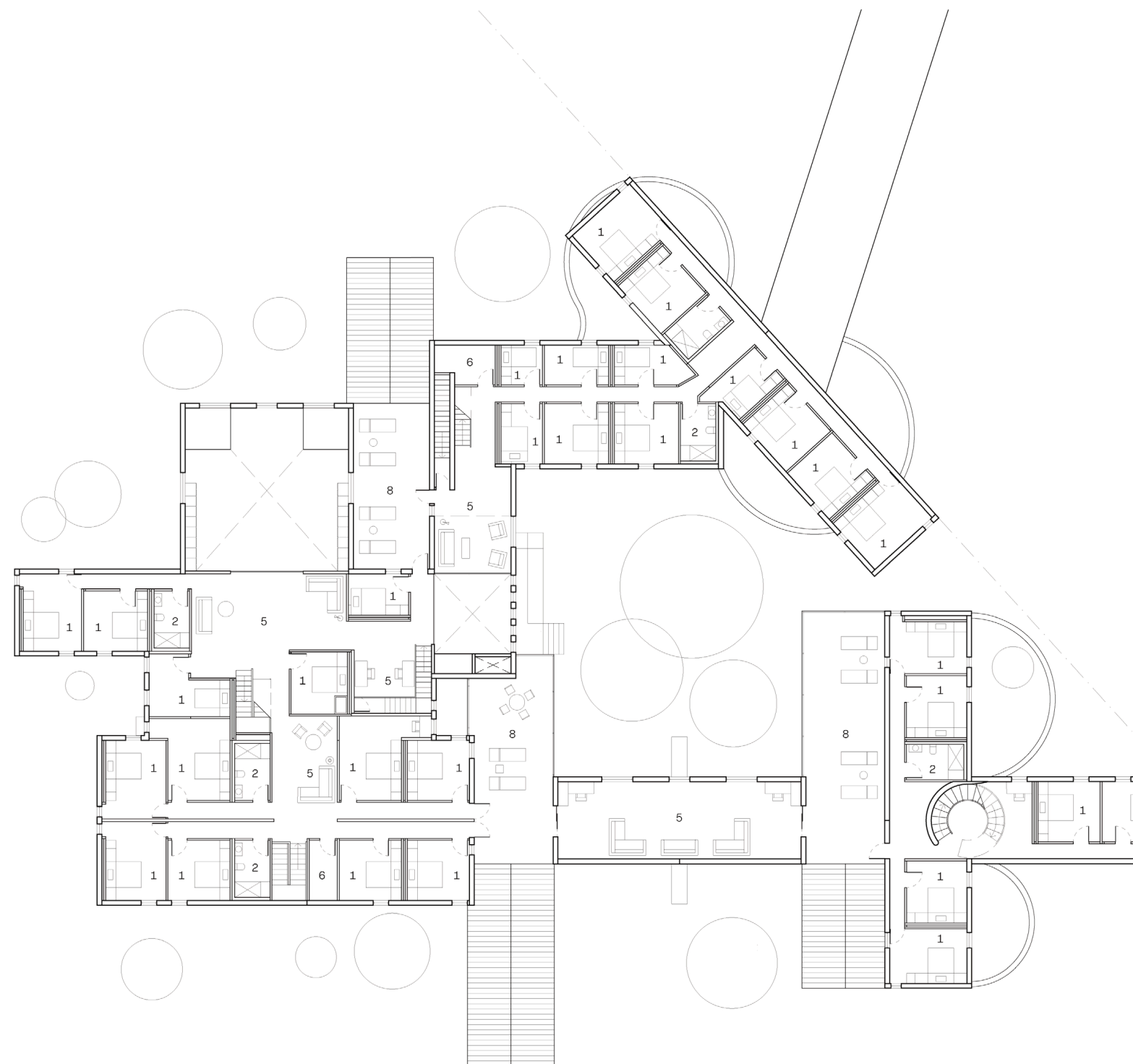

Second Floor Plan

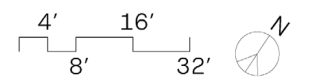

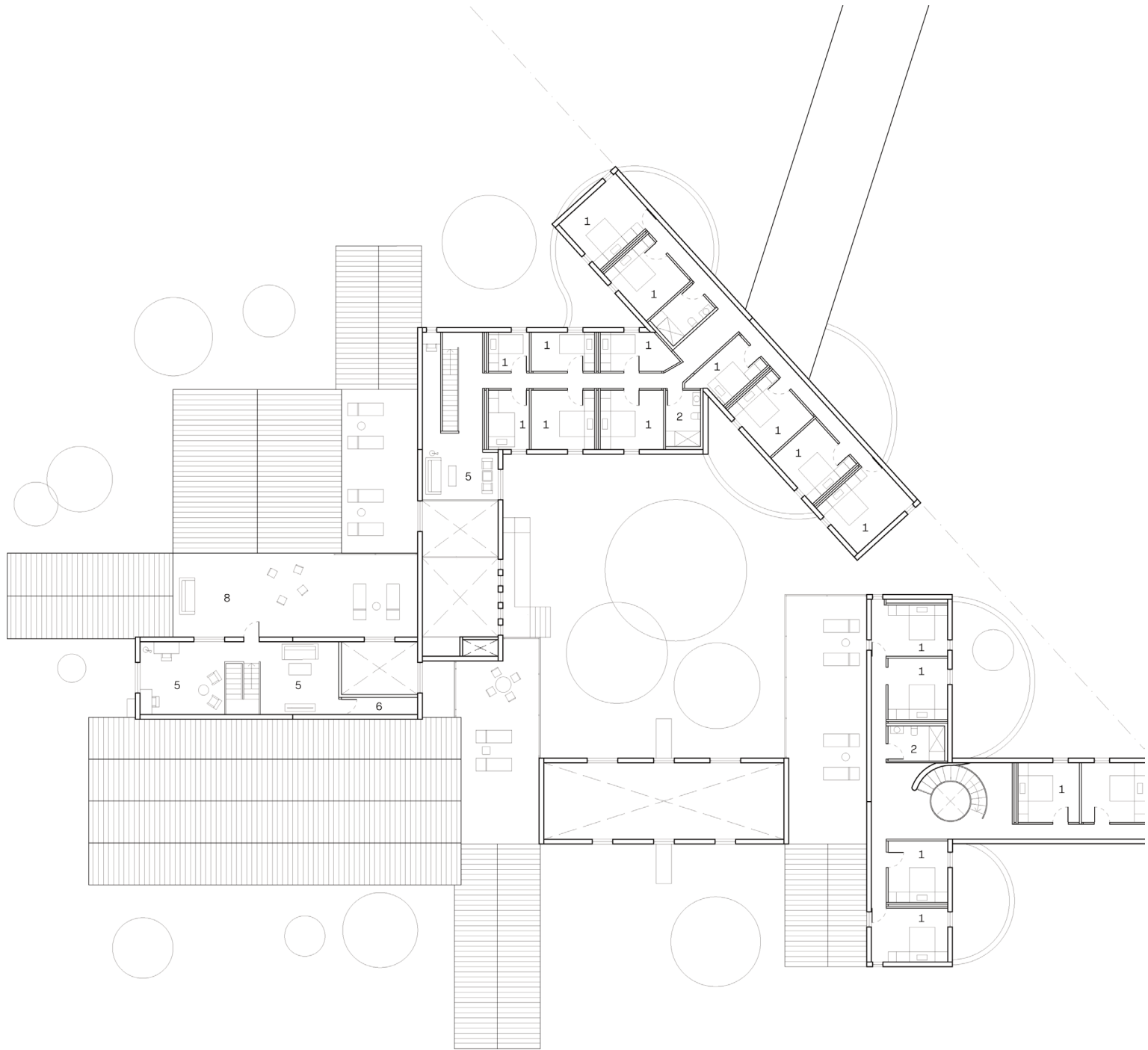

Third Floor Plan

- 1 - Bedroom
- 2 - Bathroom
- 5 - Community Living Space
- 6 - Community Storage Space
- 8 - Rooftop Deck

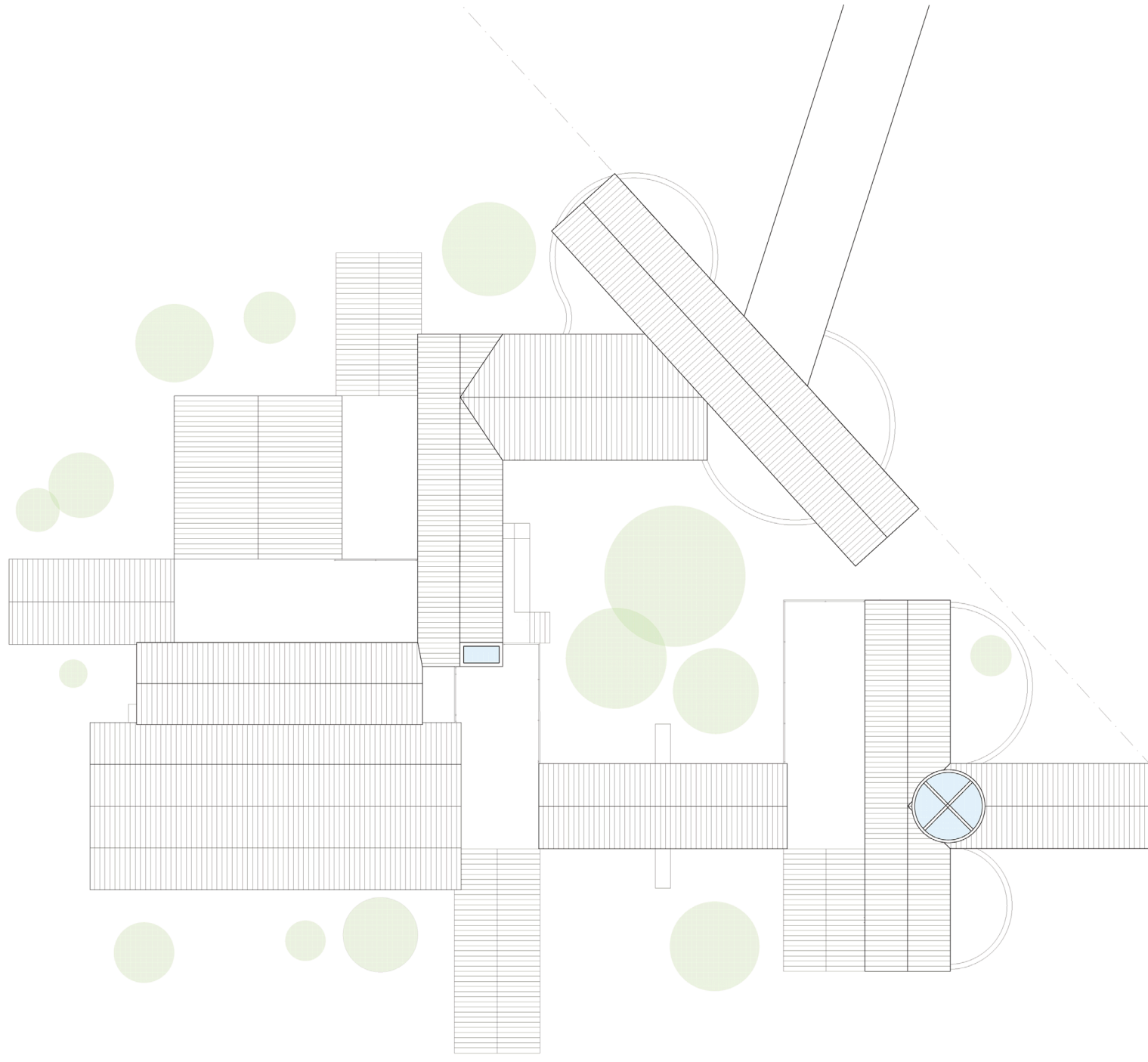

Roof Plan

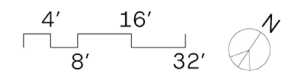



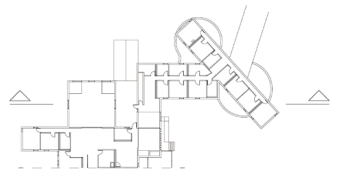
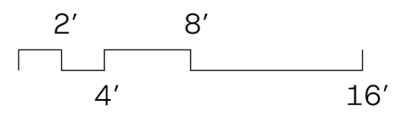
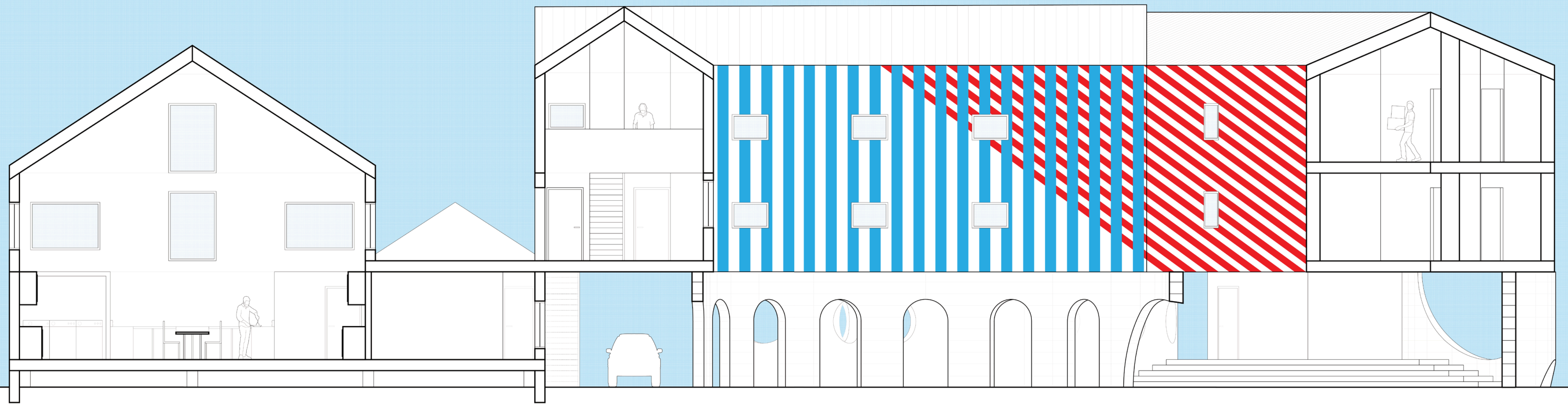











# Starting Out:

## Alley Lot Housing - Arch 602

Proposed for an unused plot in Bryan, Texas, this project posed a unique challenge. Nestled amidst the backyards of suburban housing rows, the narrow and confined site presented constraints. Our objective was to conceive low-income housing that would seamlessly integrate within this tight space, nestled in an established neighborhood.

Rather than opting for a conventional apartment complex that might disrupt the suburban fabric, the focus shifted towards crafting townhomes. While not as economically efficient as apartments, townhomes offered a more cohesive solution, striking a balance amidst various low-income housing typologies.

Designing low-income housing demands meticulous attention to detail, particularly given the small scale typically involved. Modular design emerged as a common thread, imposing stringent constraints yet fostering innovation across housing types like apartments, townhomes, and mobile homes.

Navigating these constraints as a student challenged me to optimize spatial utilization and design coherence within tight confines. The project's genesis saw a meticulous focus on bathroom design, serving as a precursor to the comprehensive modular home layout.

Subsequent phases delved into diagramming small homes, exploring diverse forms and arrangements through physical models. While time constraints limited the scope to individual homes rather than blocks of townhomes, these models scrutinized various elements including materials, layouts, and spatial openings.

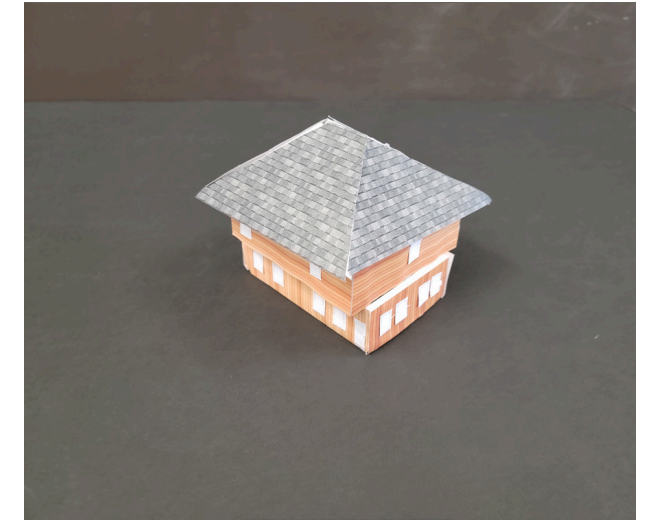
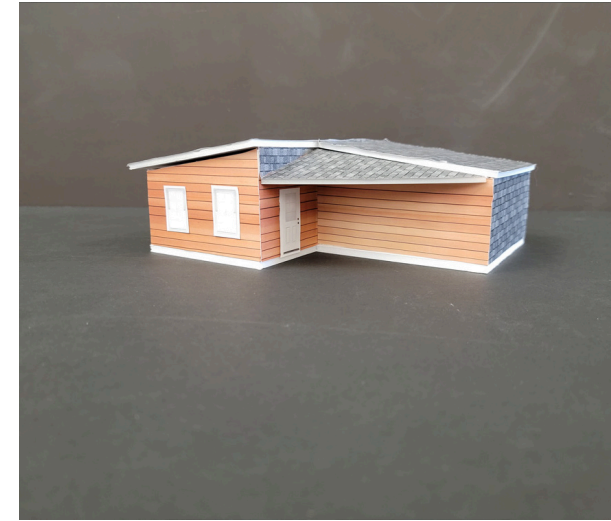



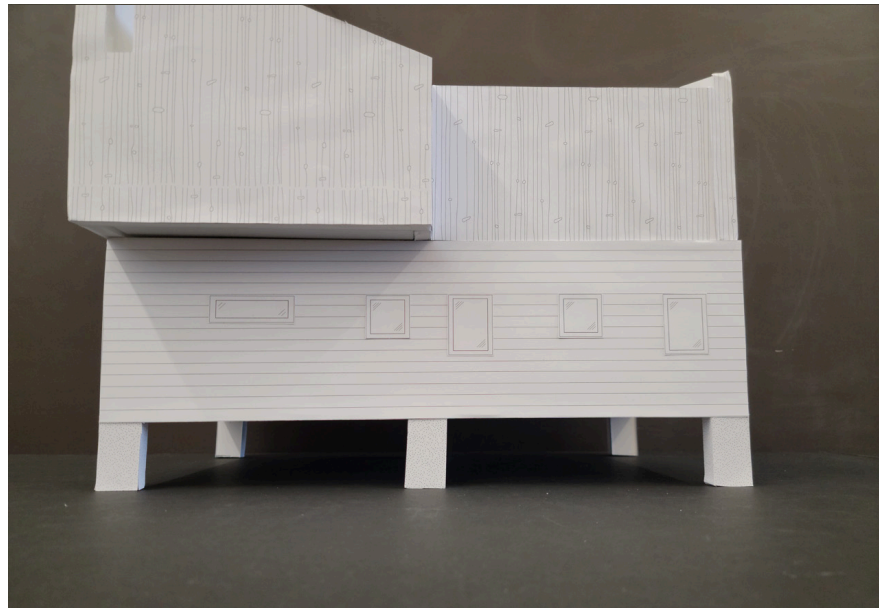
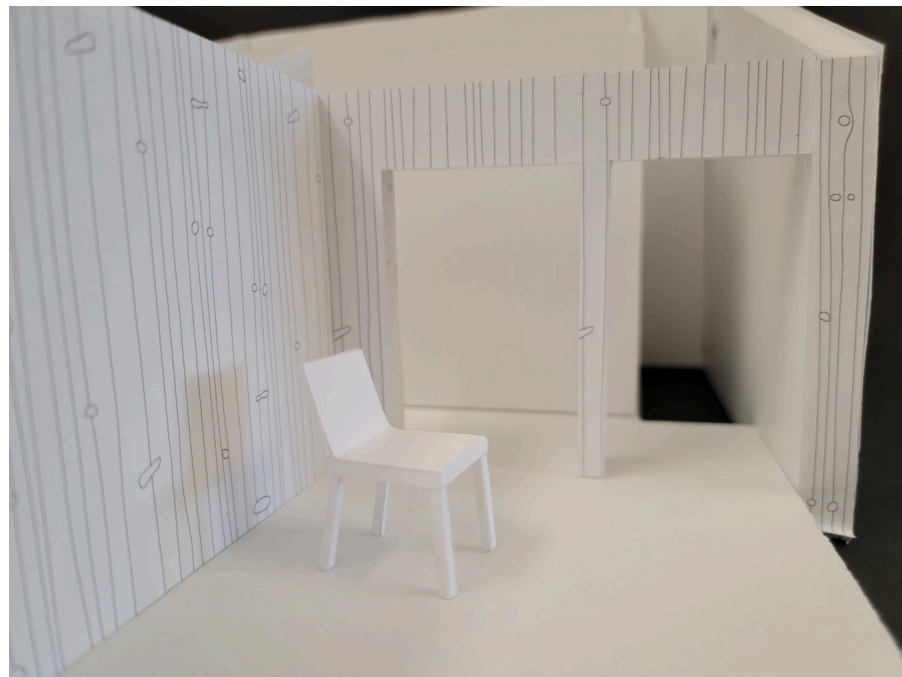
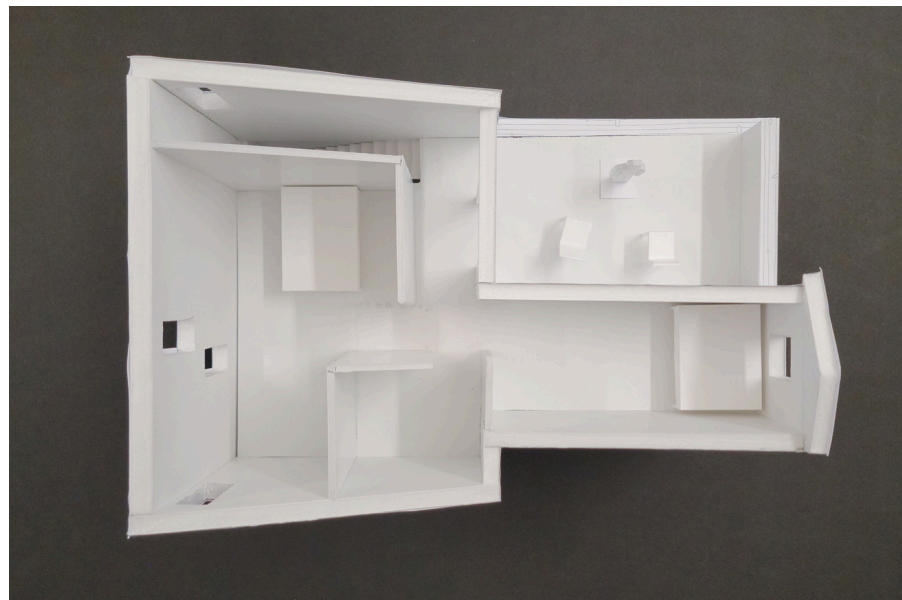

After several iterations and refinement, the final town-home design was found. The final design, incorporating lessons learned from the models and plans, was a two-story double-wide condo. This modular design was applied to the site, with minor variations in details and orientation to give each home a character of their own.

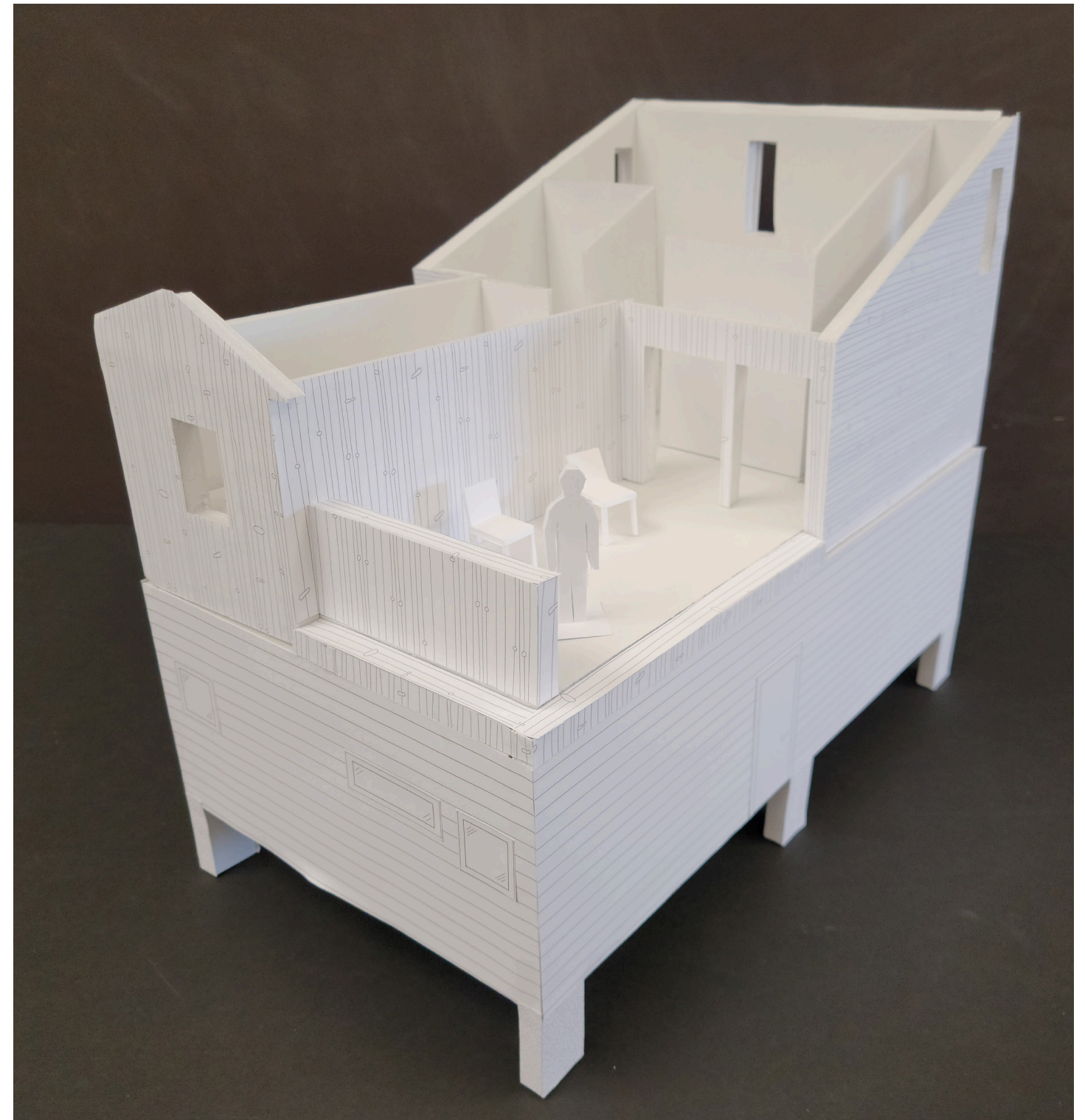



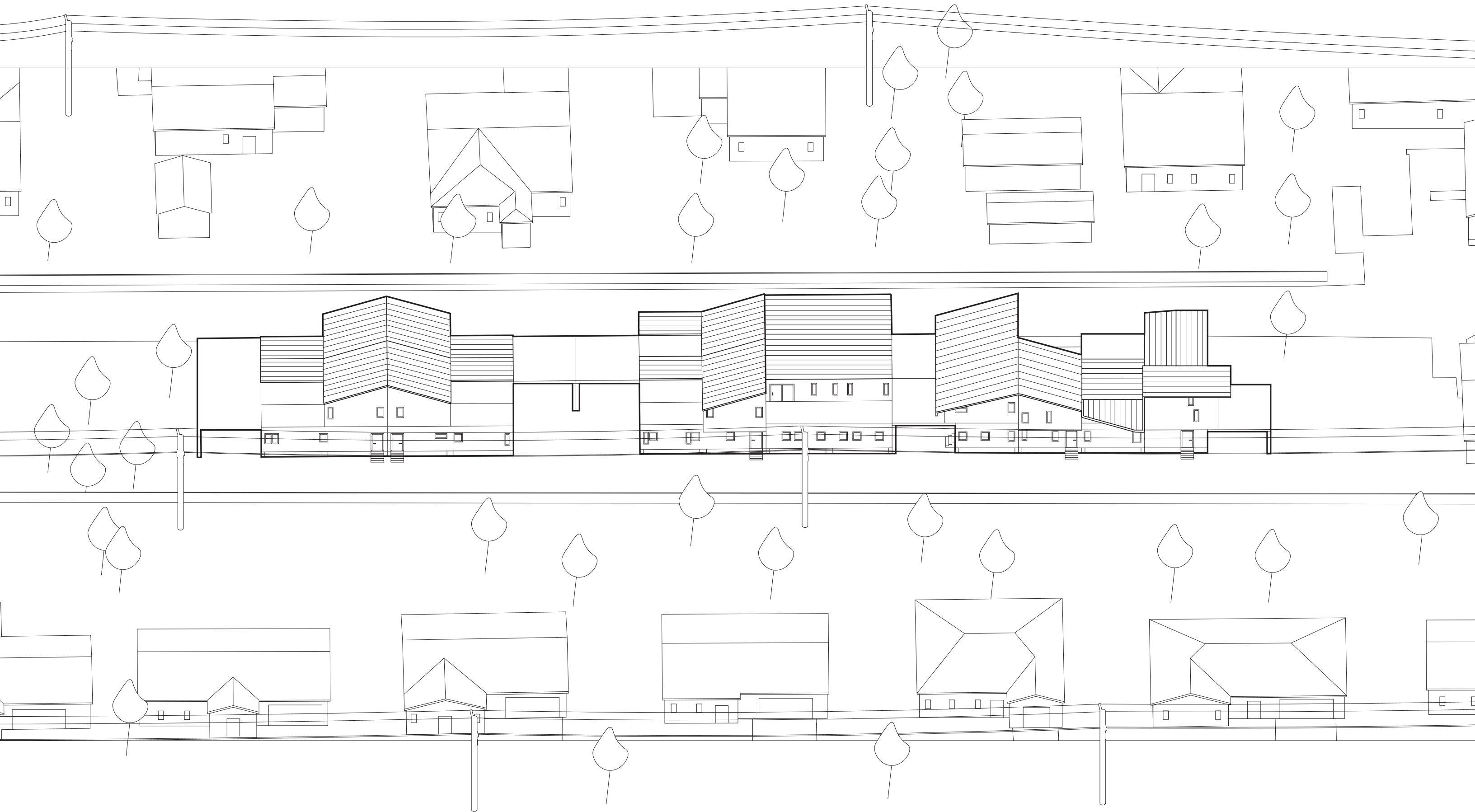

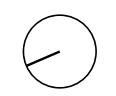
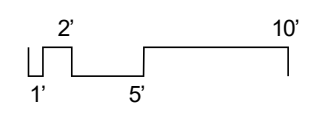
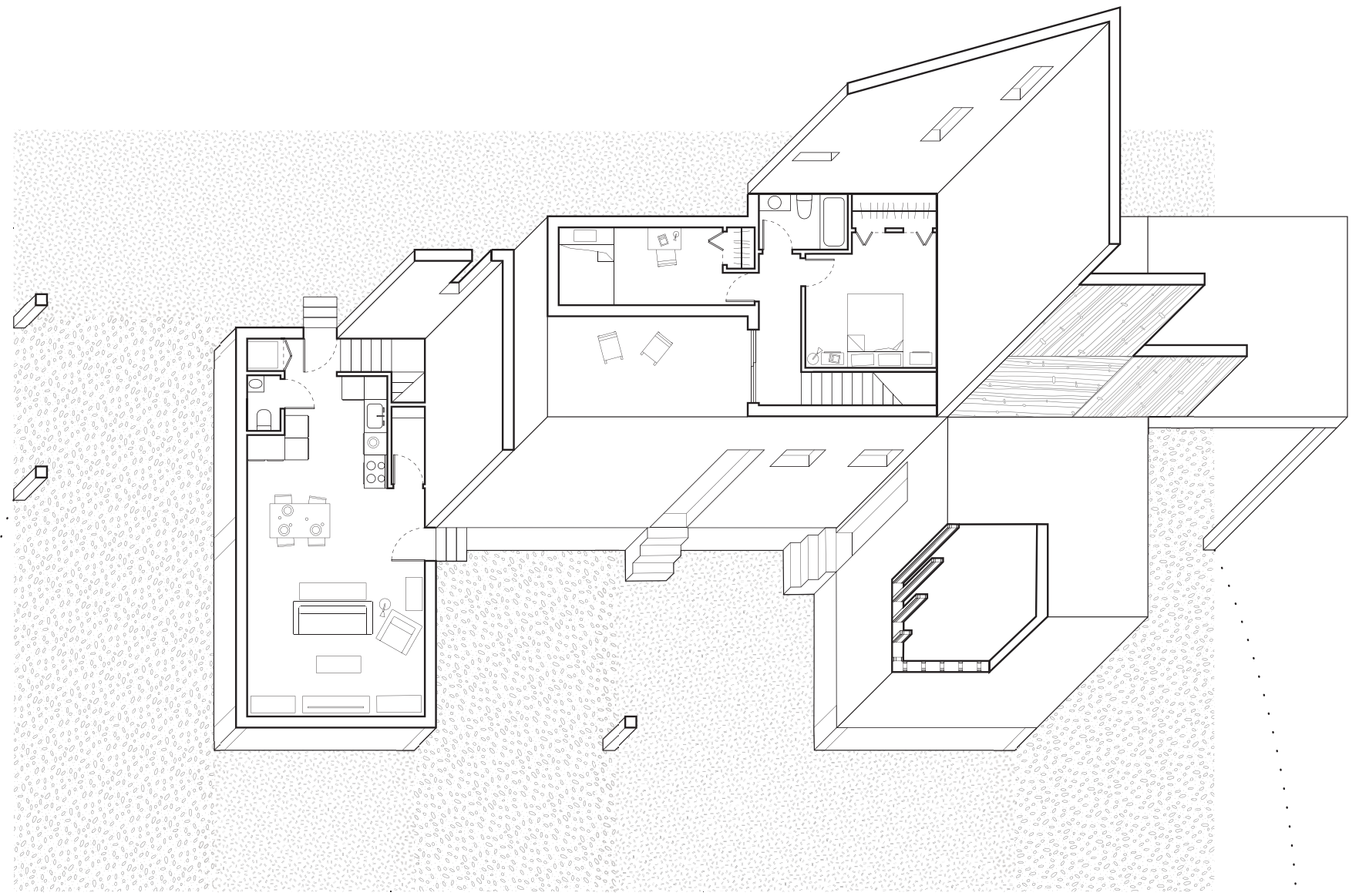

# Architecture for Art: Gallery for Downtown Bryan – Arch 603

Undertaking a distinctive endeavor, this project entails the creation of a new art gallery nestled in the burgeoning downtown area of Bryan, Texas.

The primary objective is to cultivate a vibrant cultural nucleus within Bryan, bolstering its burgeoning artistic landscape, notably through the monthly cultural extravaganza of First Fridays. Despite the presence of a few modest independent artist studios, the absence of a large-scale art venue prompted the endeavor to establish a pivotal cultural destination within the heart of the city.

Pioneering an unconventional approach, the project was conceptualized in sectional form under the guidance of a professor, preceding all other design endeavors. This unique methodology culminated in a striking ramp-style gallery design, drawing inspiration from the iconic Guggenheim Museum by Frank Lloyd Wright.

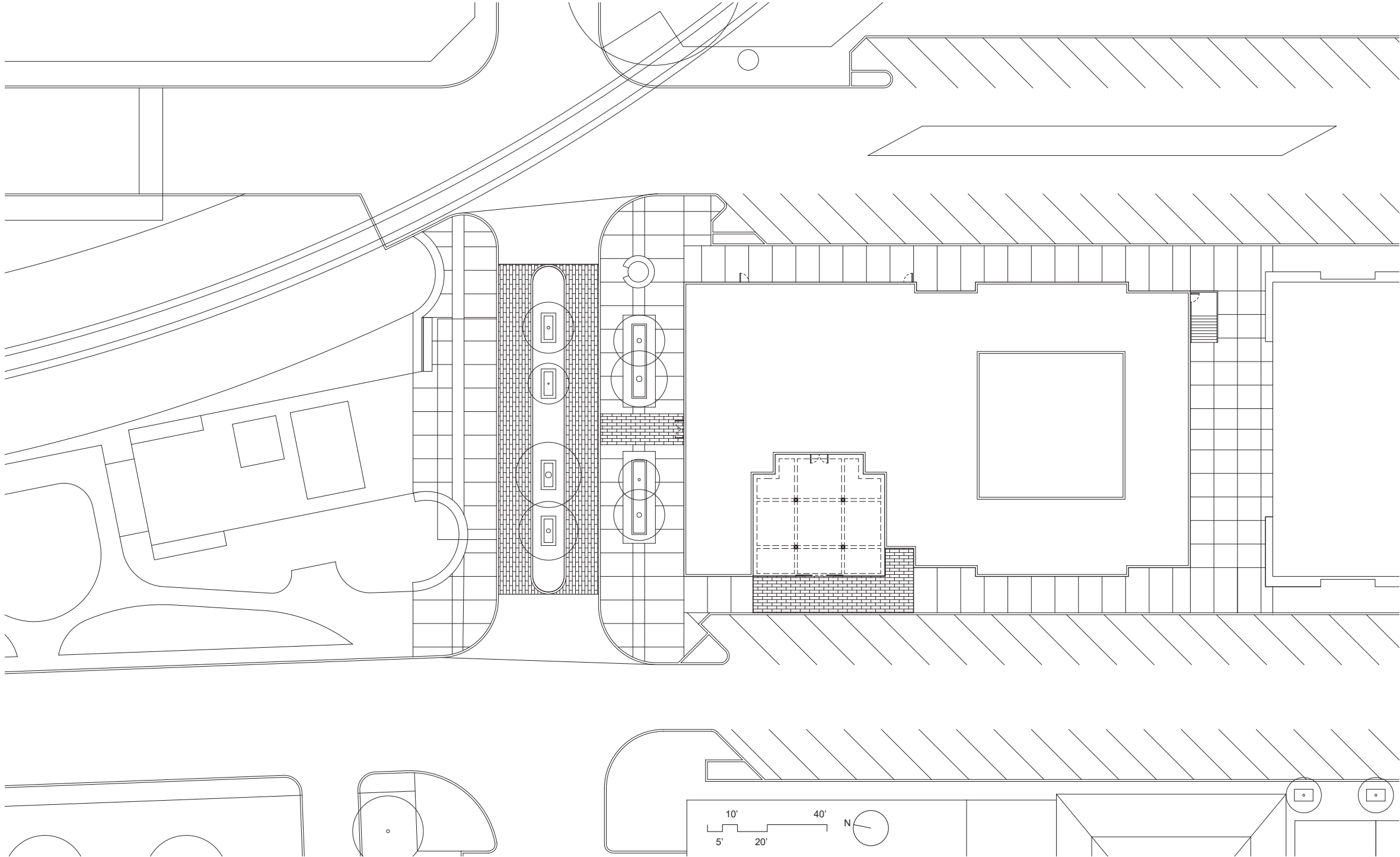



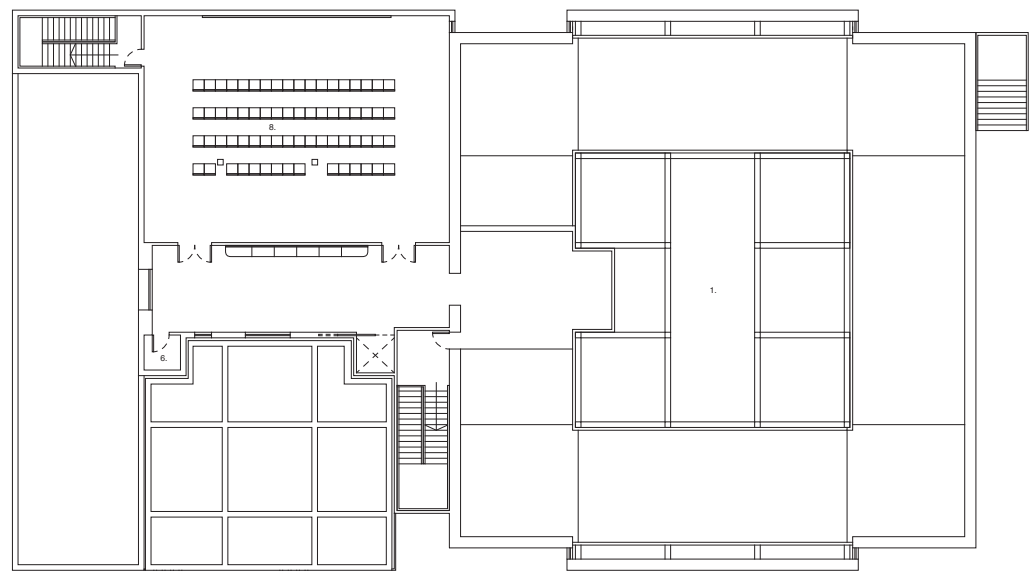

Ground Floor

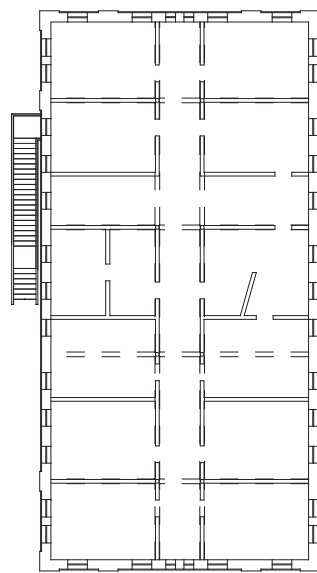

2nd Floor

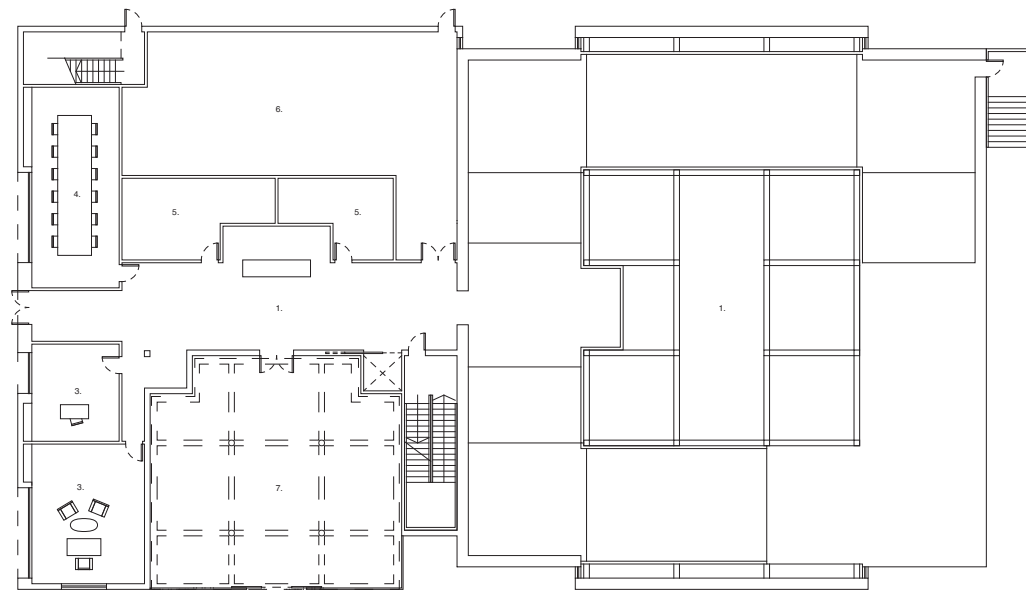
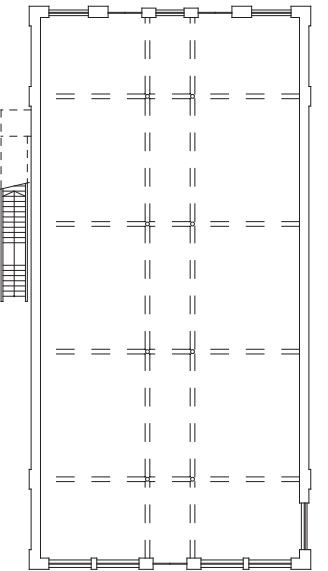

- 1. Mega-Giga Gallery
- 2. Reception
- 3. Offices
- 4. Conference Room
- 5. Bathrooms
- 6. Storage
- 7. Covered Giga Patio

- 1. Mega-Giga Galley
- 6. Storage
- 8. Multi-use Space

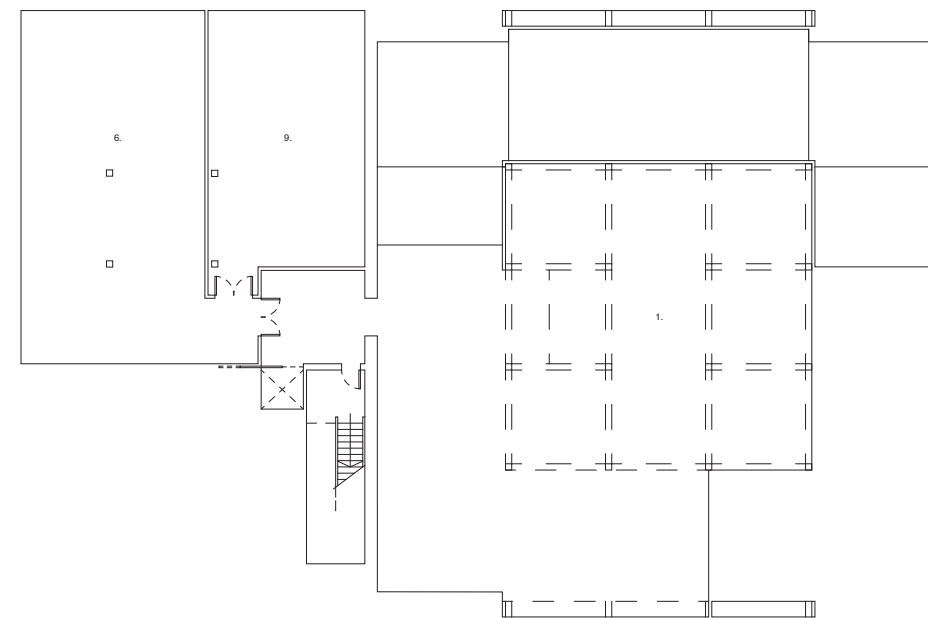

Basement/Sub Floor

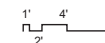

- 1. Mega-Giga Gallery
- 6. Storage
- 9. Mechanical Room

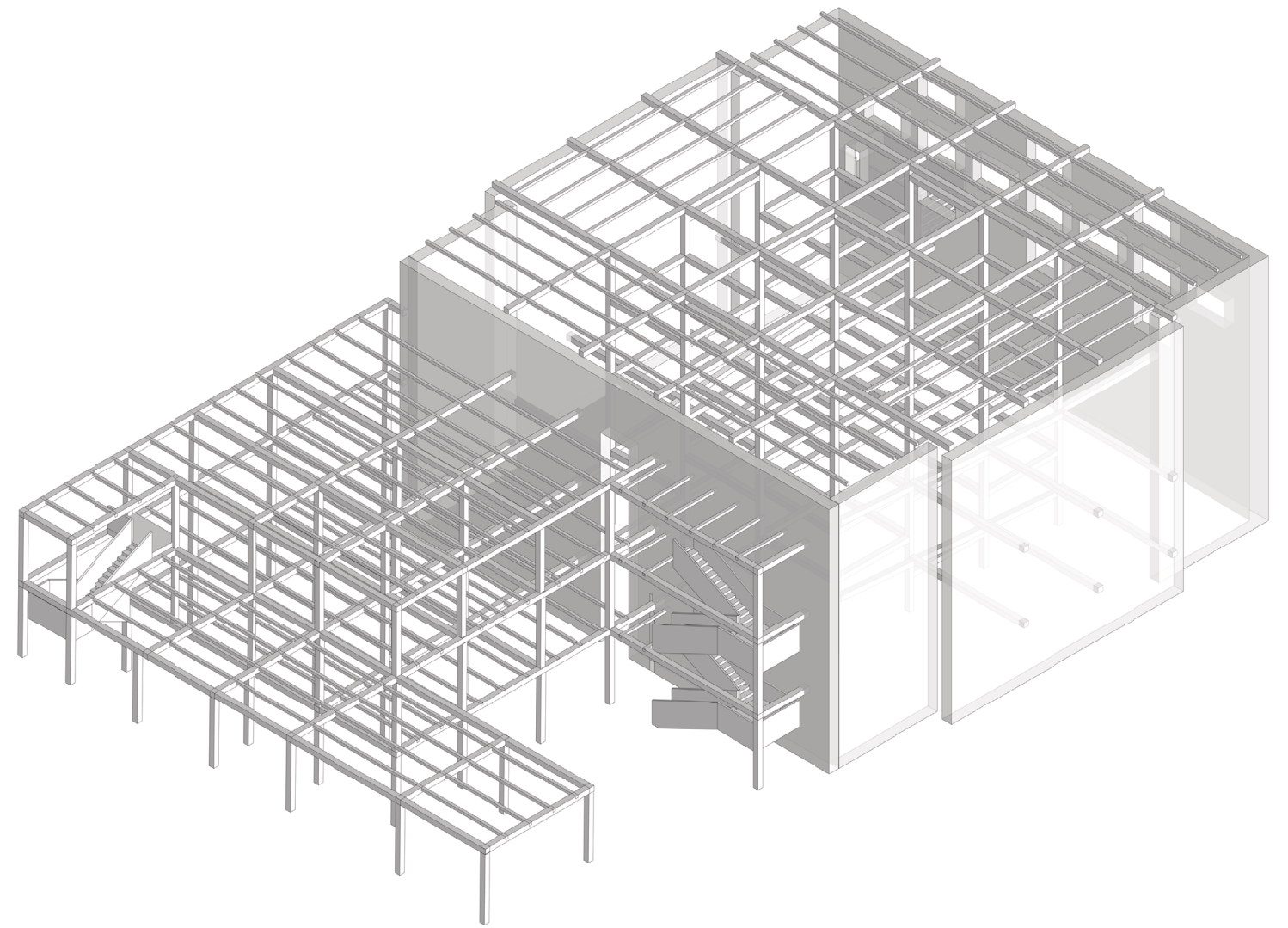
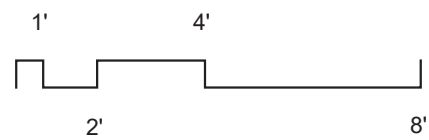
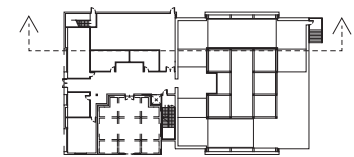
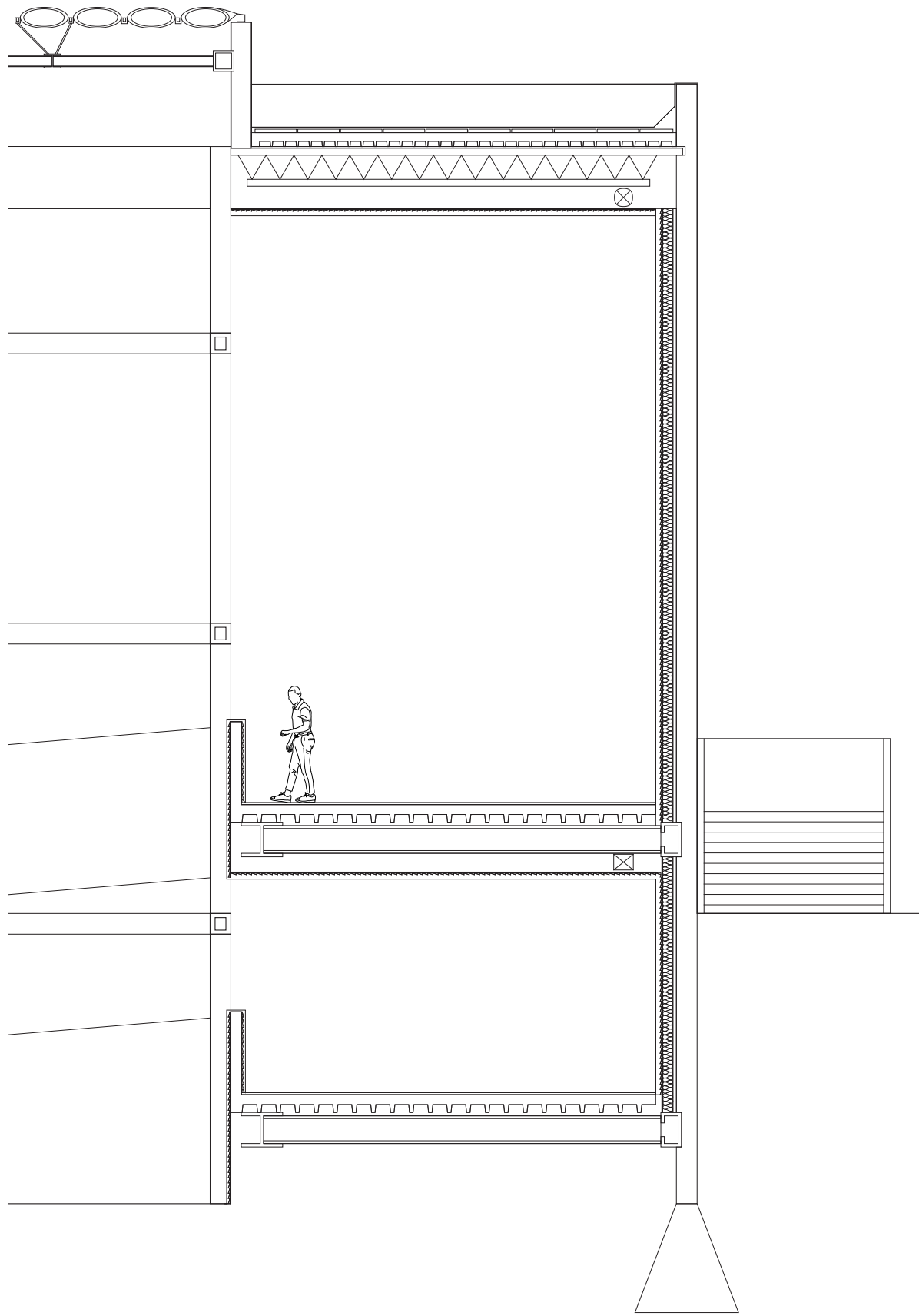

NTS

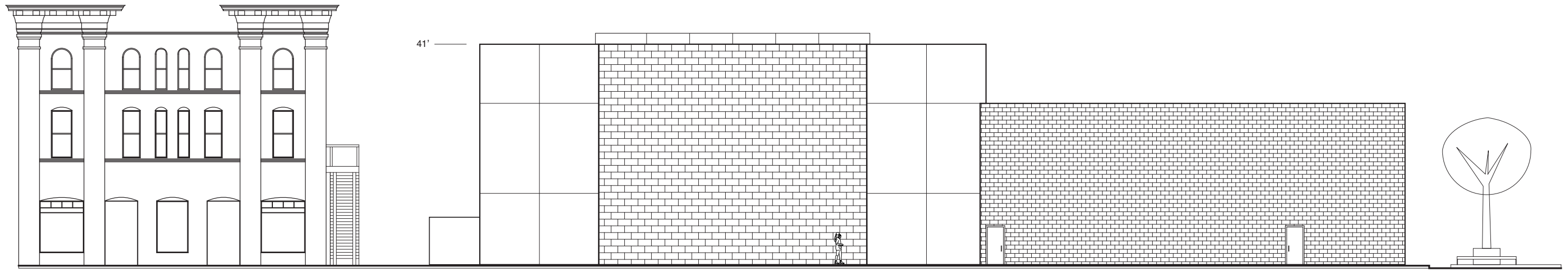

West Elevation

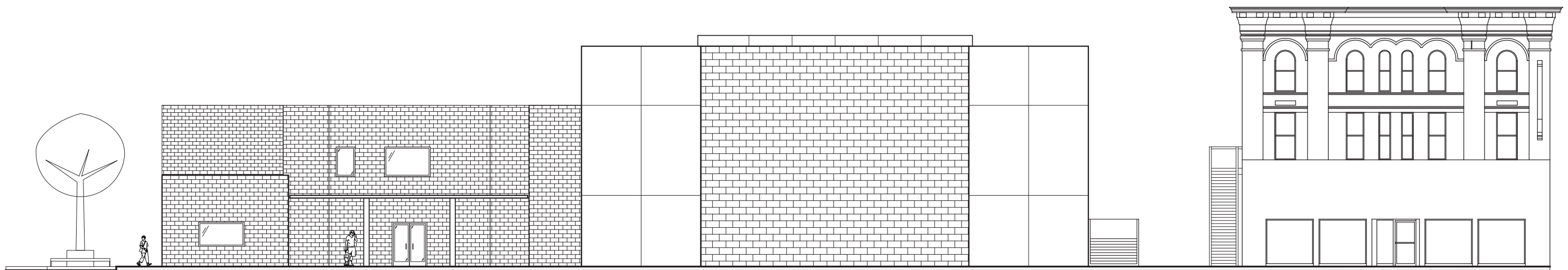

East Elevation

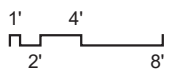

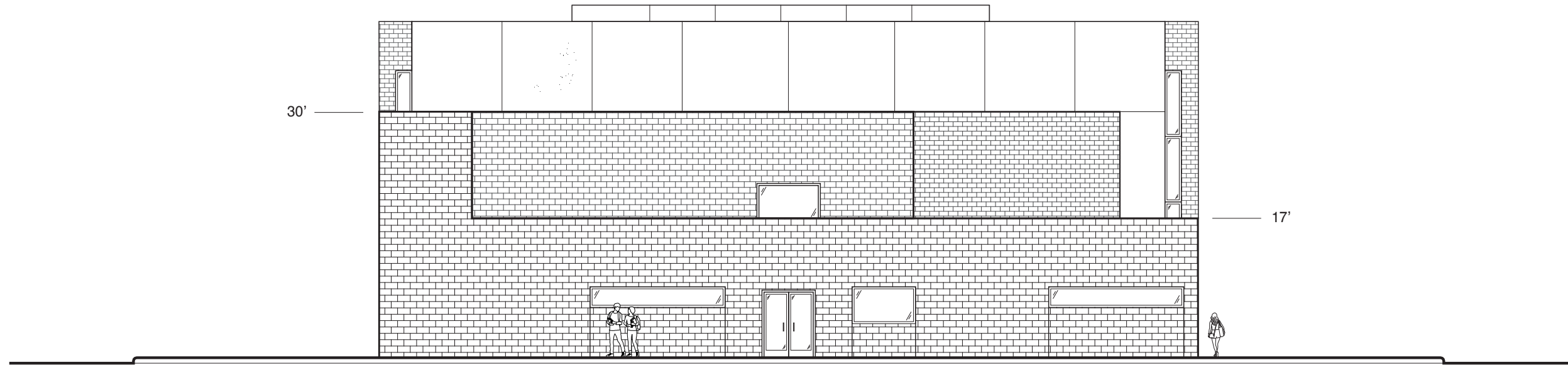

South Elevation

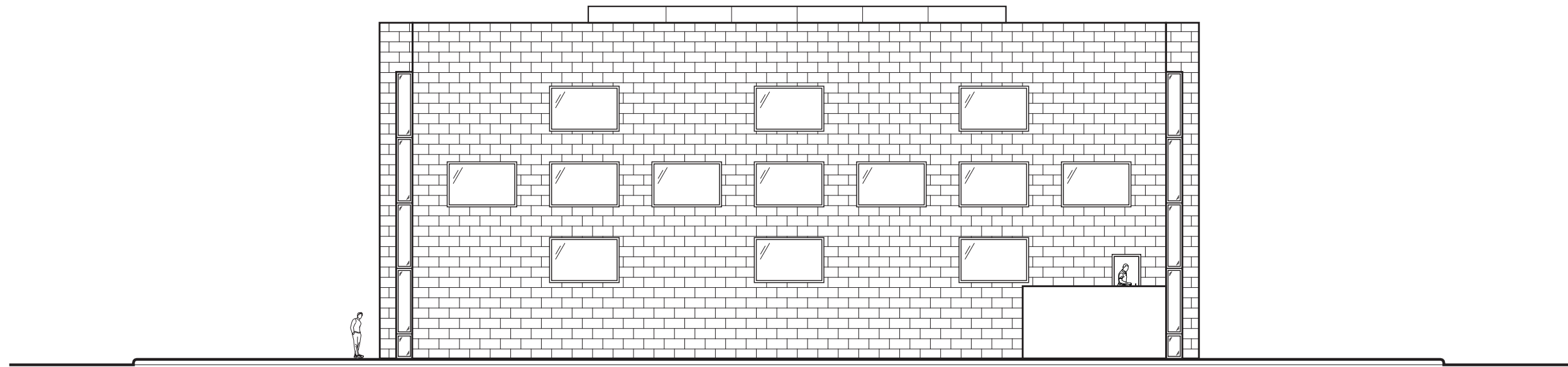

North Elevation

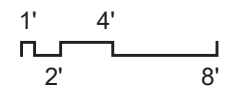



# Art for Architecture: Community Center in Dallas – Arch 605

This project represents a distinctive fusion of community functionality and artistic expression, seamlessly blending the roles of a community center and an art gallery. Situated in the industrial heart of downtown Dallas near Deep Ellum, its purpose is to serve as a nucleus for the local community, offering amenities such as a library, workshop, conference space, cafe, and auditorium. In addition to these communal spaces, the facility boasts both indoor and outdoor exhibition areas meticulously crafted to showcase the renowned works of Donald Judd, complete with archival space for pieces not currently on display.

Designed to harmonize with its industrial surroundings amidst warehouses, train tracks, and highways, the project encapsulates the essence of its locale while paying homage to Judd’s artistic legacy.

Prefabricated metal buildings were strategically employed, not only for their cost-effectiveness and eco-conscious attributes but also to honor Judd’s ethos of utilizing existing materials. The resulting architectural composition comprises a dynamic interplay of stacked metal structures interspersed with open areas dedicated to both artistic exhibitions and community engagement.

Save for select structural elements, the entire project is crafted from prefabricated building systems sourced from Butler Manufacturing. Furthermore, in alignment with Judd’s philosophy, each exhibition space was meticulously tailored to accommodate Judd’s pieces, with the art itself dictating the architectural form and flow.

The outcome is a symbiotic fusion of art and architecture that remains faithful to the principles espoused by Donald Judd. By seamlessly integrating prefabricated building systems and meticulously curating exhibition spaces, this project not only stands as a testament to innovative design but also serves as a profound tribute to Judd’s enduring legacy.

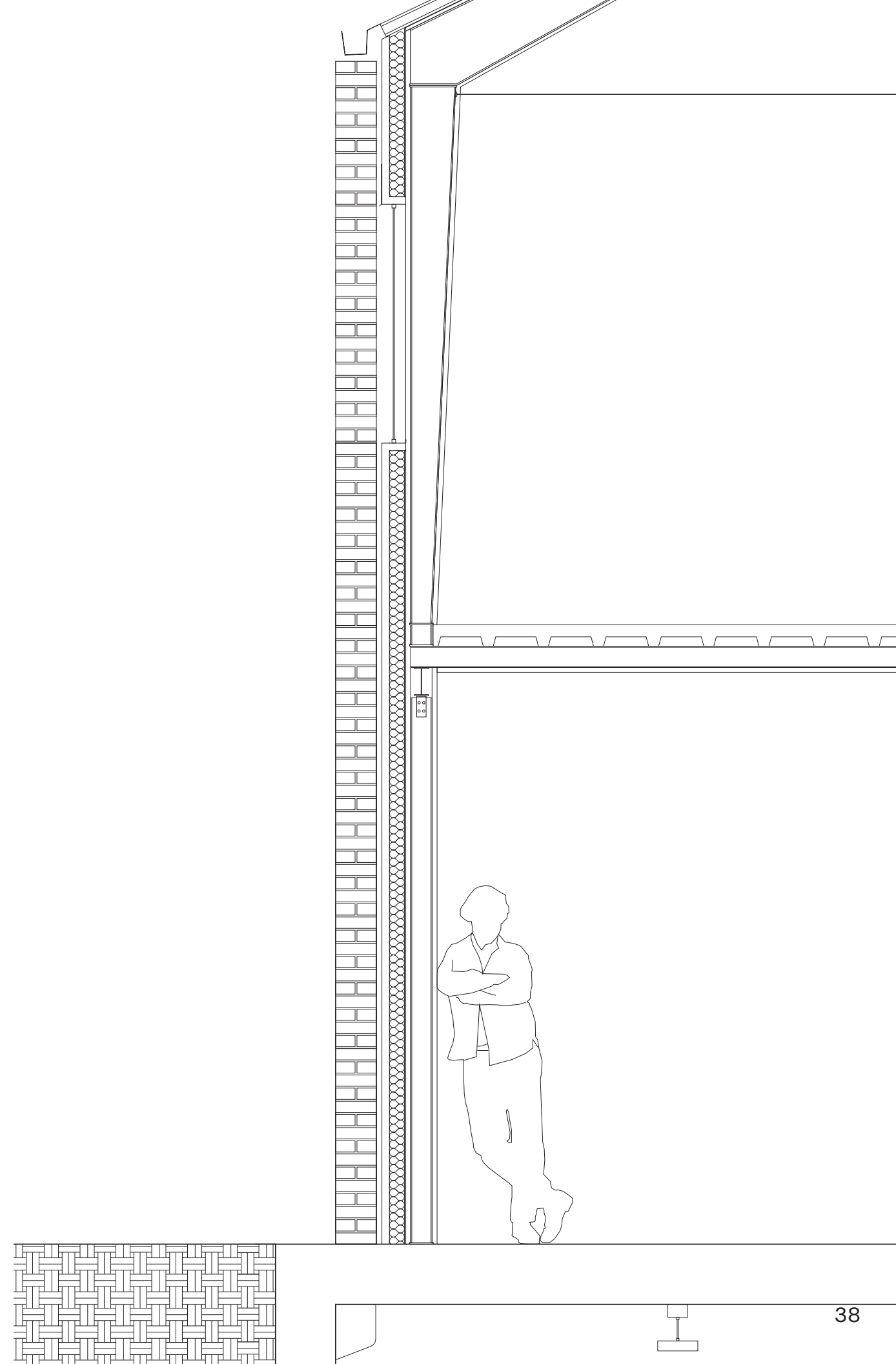

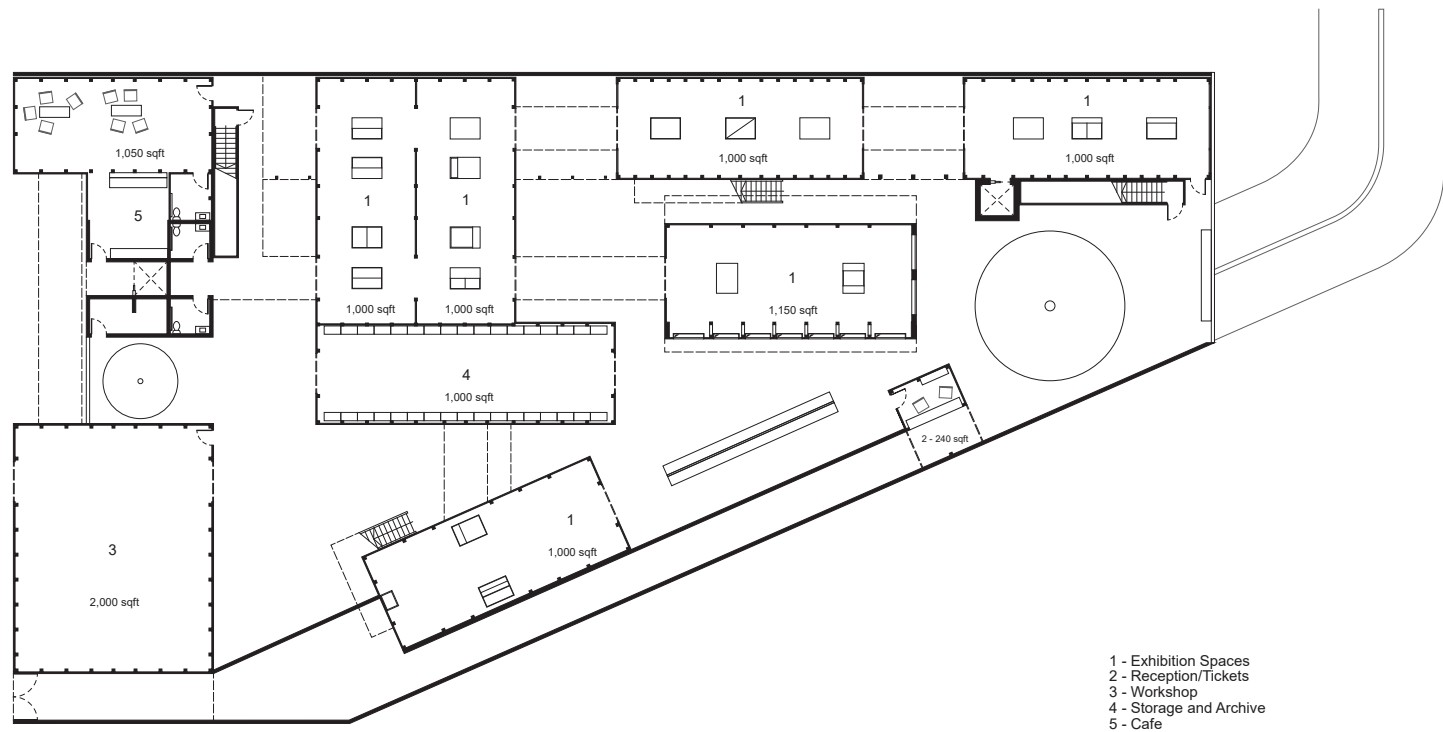

10' 40'  
 5' 20' Ground Floor Plan

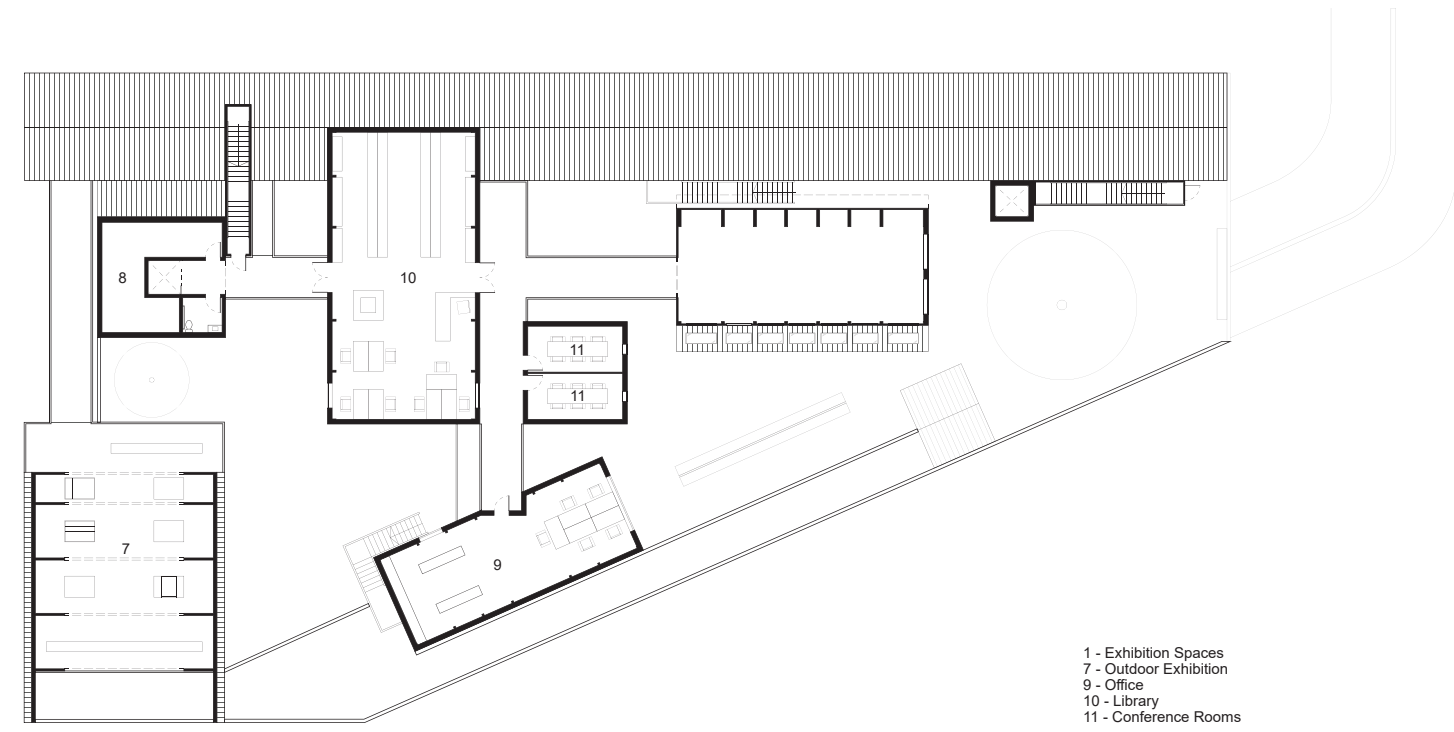

10' 40'  
 5' 20' Third Floor Plan

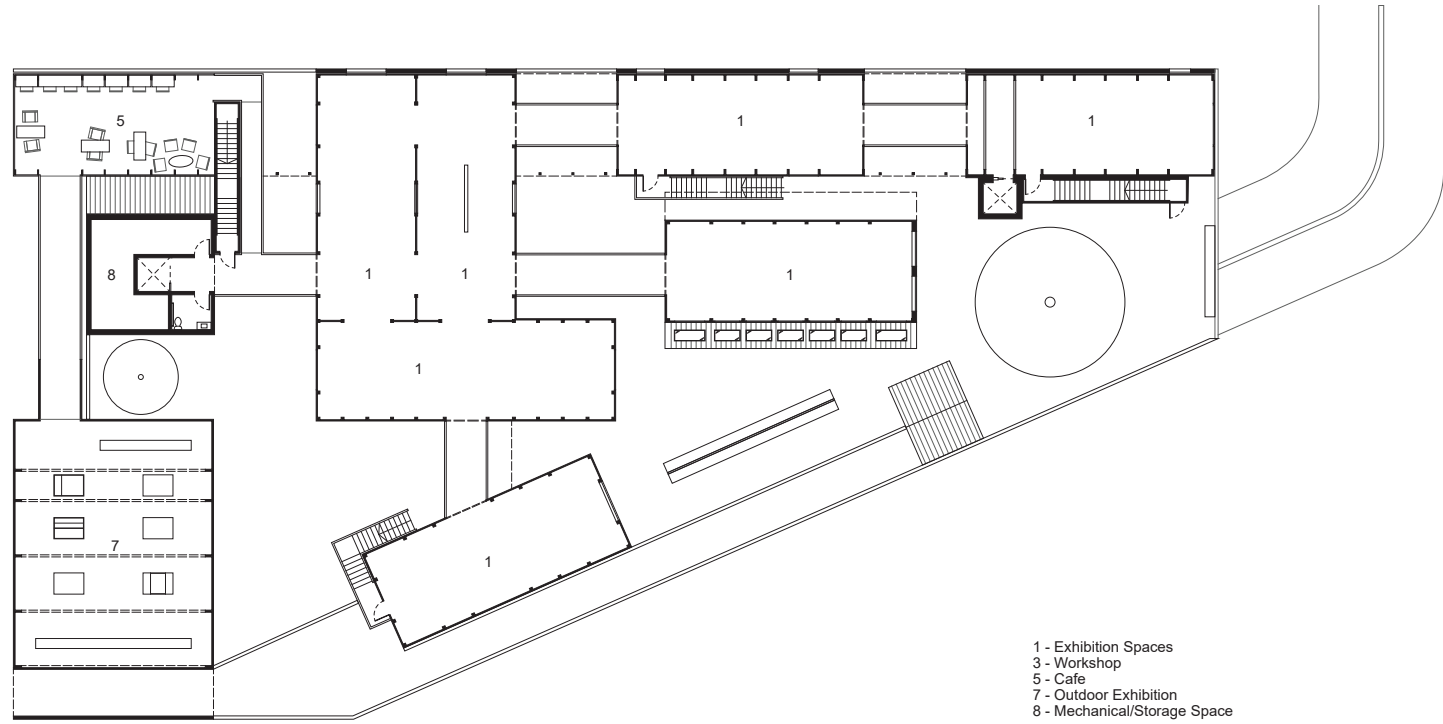

10' 40'  
 5' 20' Second Floor Plan

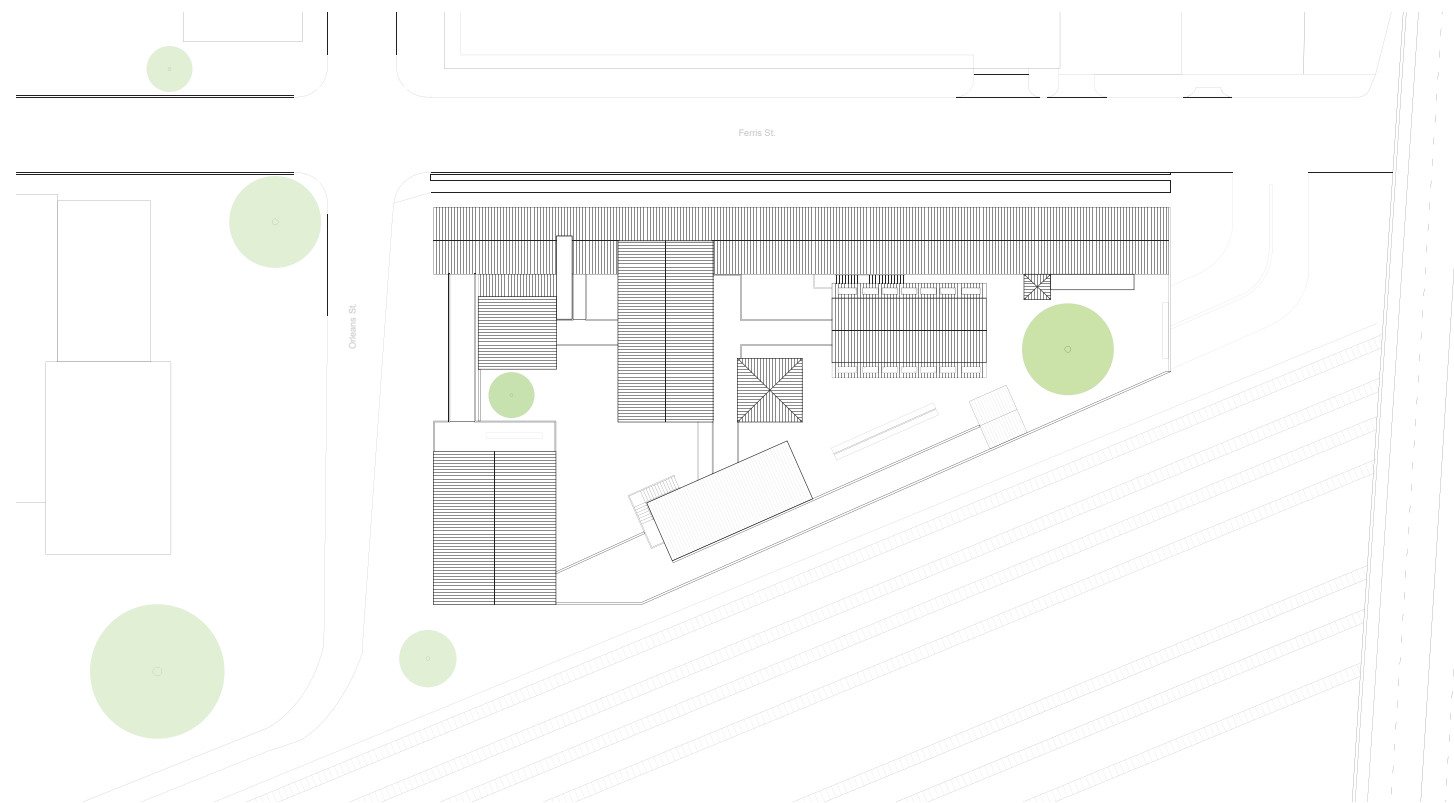

Topofdoublewall

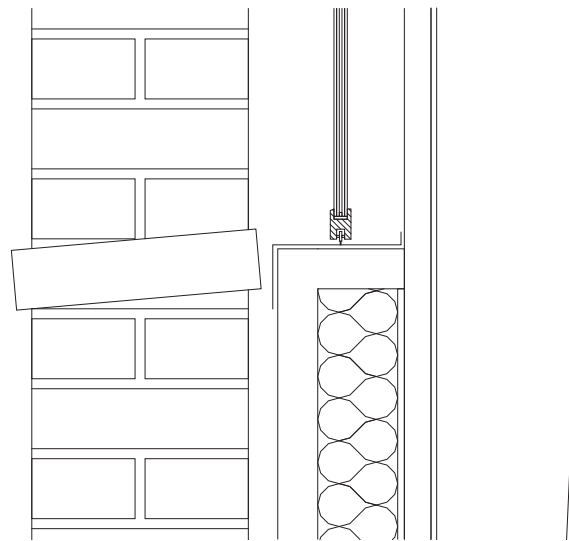
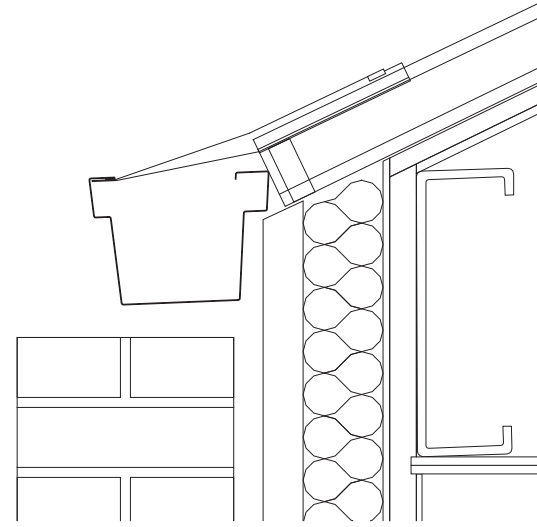

Bottomofdoublewallopenings

Bottomofdoublewall

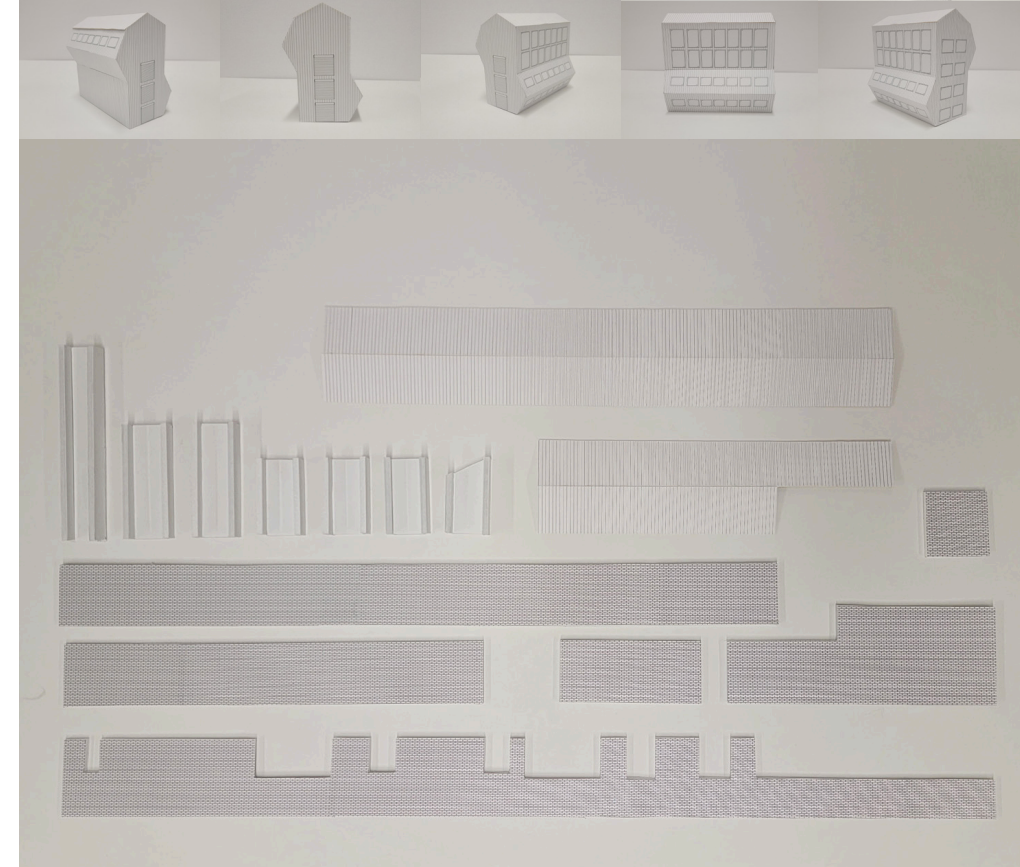
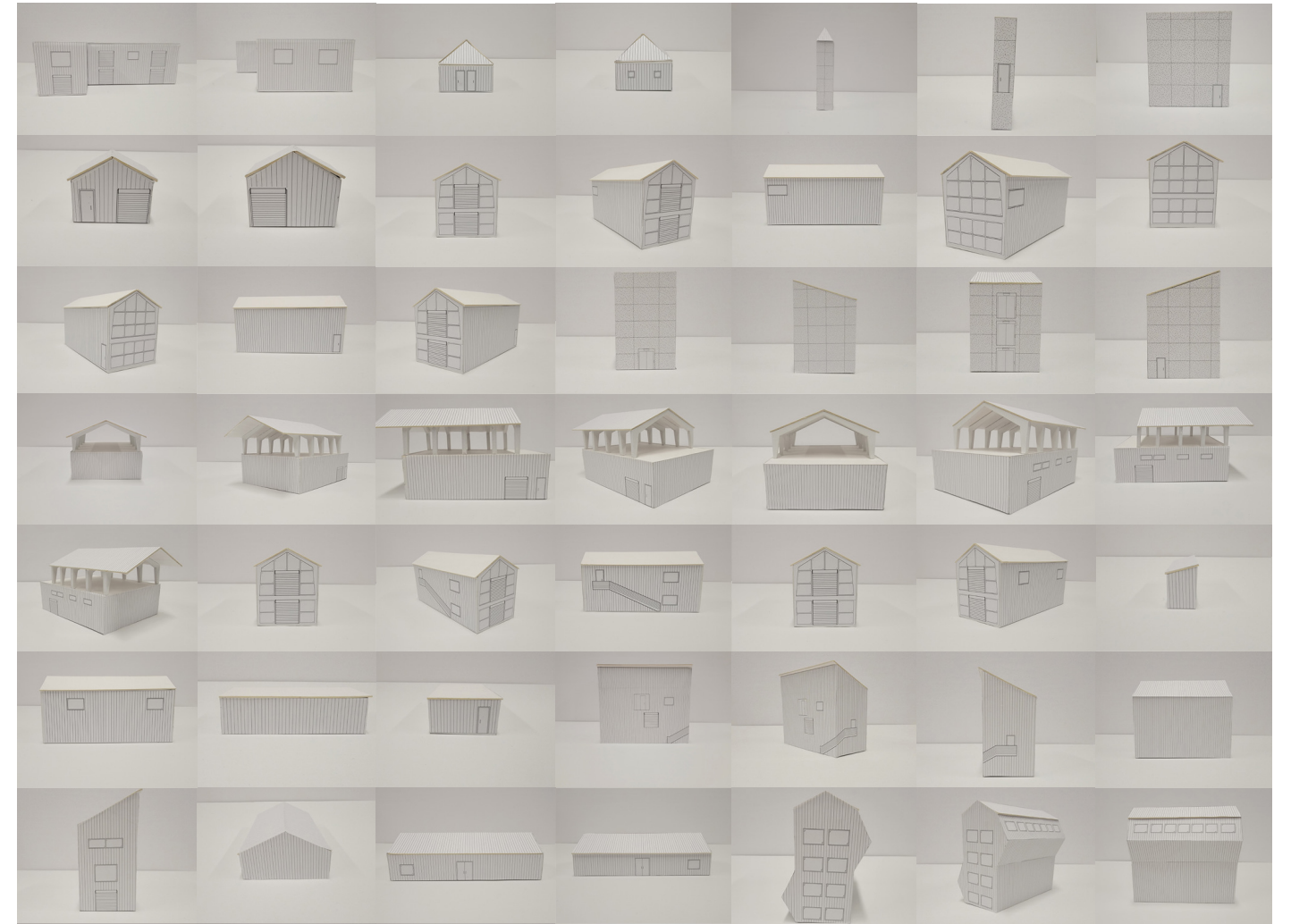
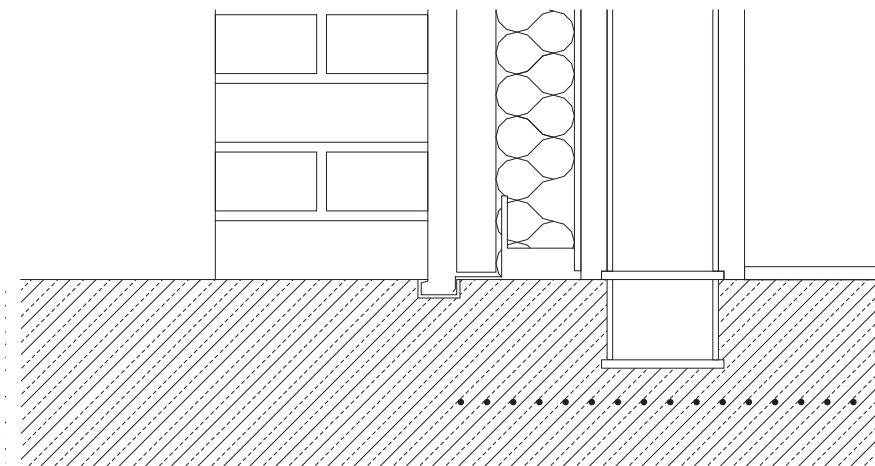

As the project was made of so many separated buildings and elements, I felt it necessary to create a physical model in order to fully express the building(s).

Here, you can see all the parts of the project before they were assembled.



The perimeter wall was built partly in response to the rough, high-crime site in which it's housed. The wall, designed also to serve as a canvas for community artists, encloses the buildings together and offers one main entrance. The long, enclosed pathway invites people of the community into their metal castle, offering a feeling of adventure while demarcating the campus of community buildings.

